

Fluorescence hyper-résolue de molécules uniques avec un STM.

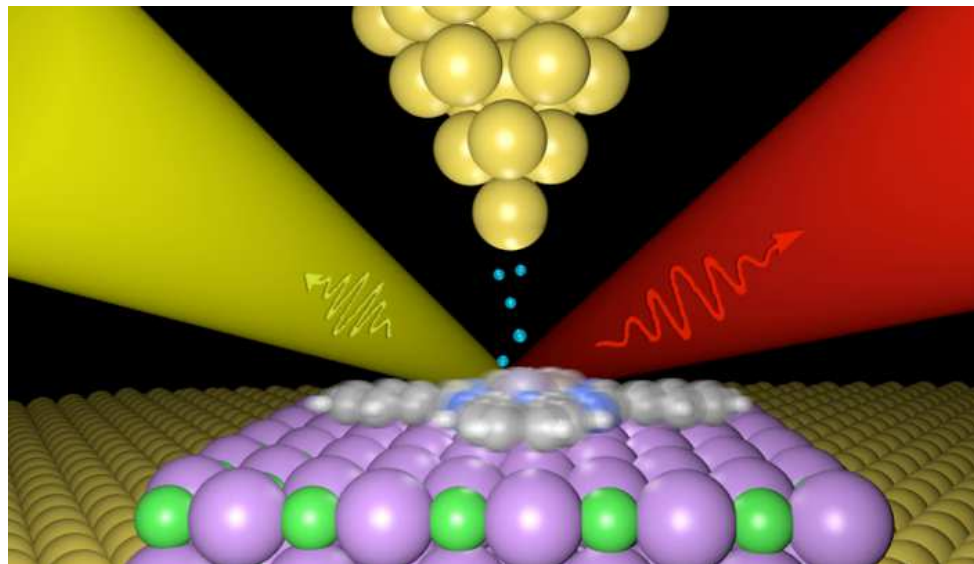

Guillaume Schull

Institut de Physique et de Chimie des Matériaux de Strasbourg (IPCMS)

<http://www-ipcms.u-strasbg.fr/stmipcms/>

Single-molecule fluorescence

"Even with the best possible optics we can never even come close to a resolution corresponding to the dimensions of a single molecule (sub-nanometer scale)"

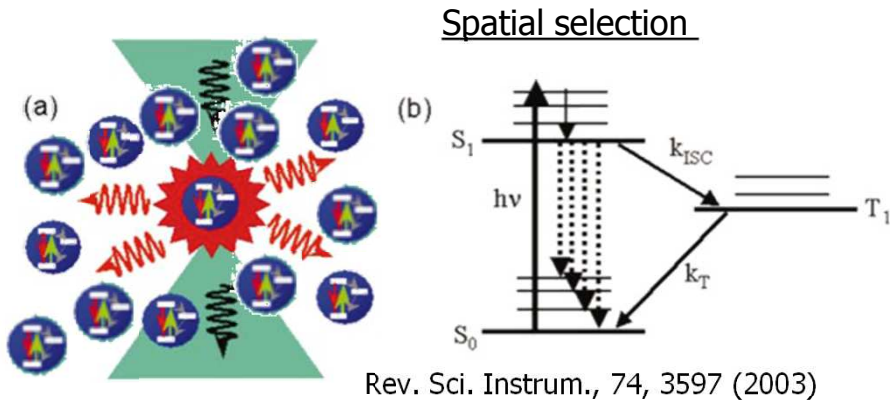

Web-page of Michel Orrit

<https://www.single-molecule.nl/notes/the-principles-of-single-molecule-detection/>

- Can we question this statement ?
- If yes, what could we learn ?

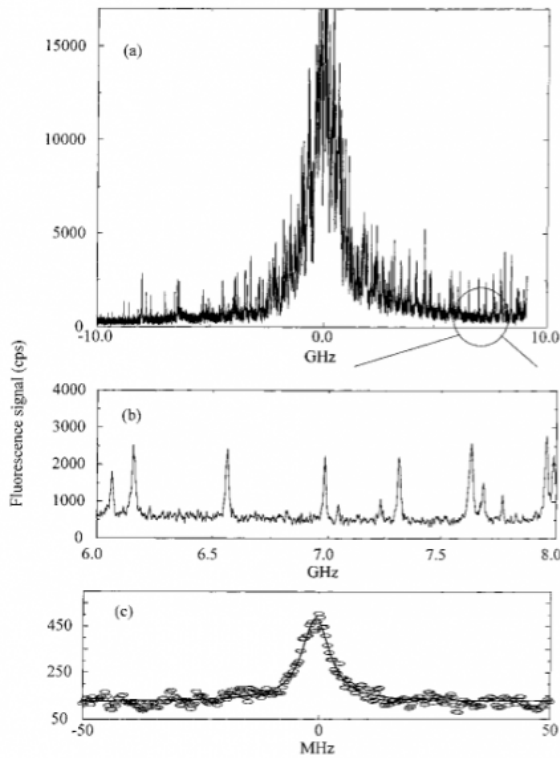

W.E. Morener and L. Kador
Phys. Rev. Lett. 62, 2535 (1989)

M. Orrit and J. Bernard
Phys. Rev. Lett. 65, 2716 (1990)

Spectral selection

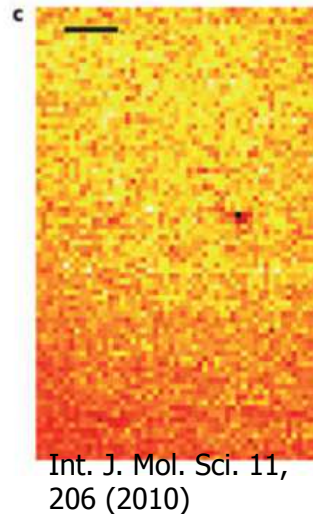

2014 Nobel Prize in Chemistry
E. Betzig, S.W. Hell, W.E. Moerner
"for the development of super-resolved fluorescence microscopy".

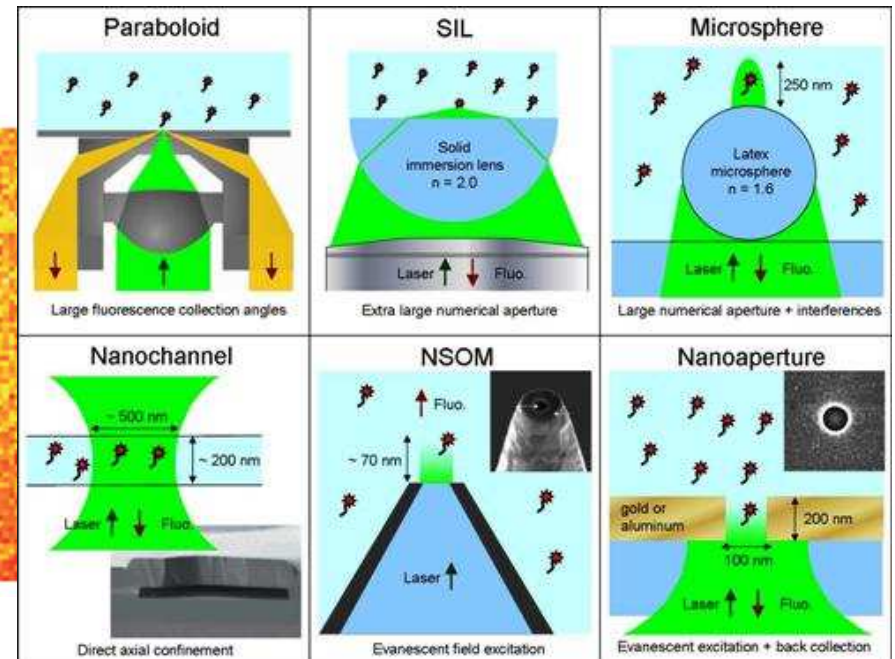

Light emission from STM junctions

Metal-oxide-metal tunnel junction

J. Lambe and M.L. McCarthy
Phys. Rev. Lett. 37, 923 (1976)

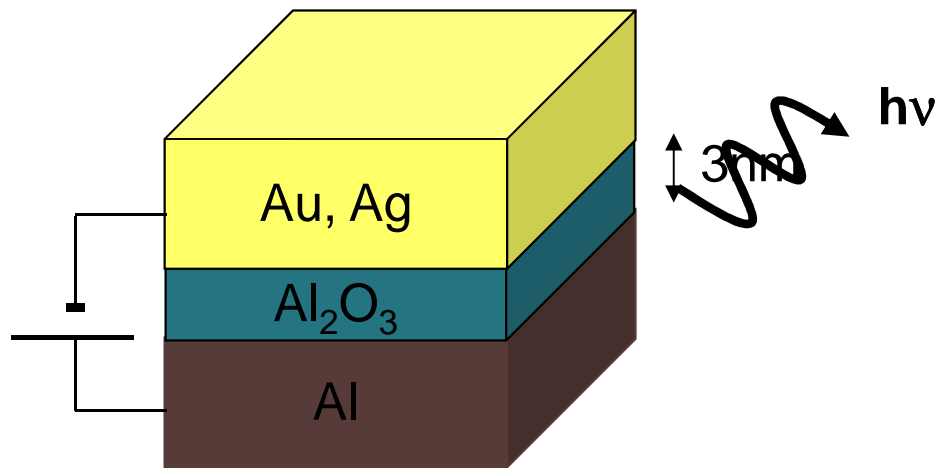

Photons emitted are intimately linked to the tunnel electrons !!

Localized source of tunnel electrons: STM

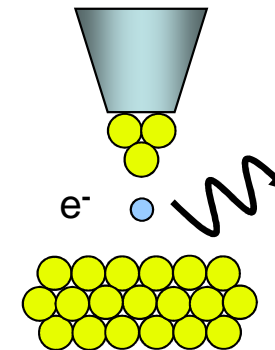

J. Gimzewski *et al.*
Z. Phys. B - Cond. Matt. 72, 497 (1988)

Si(111), metal (polycrystalline surfaces)

Light emission from STM junctions

Molecules

$$h\nu = \text{LUMO} - \text{HOMO}$$

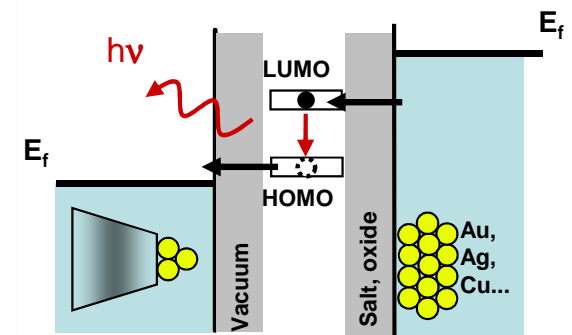

STM-induced light emission

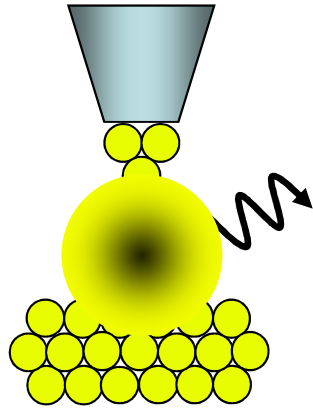

Photon counting regime

STM-induced light emission

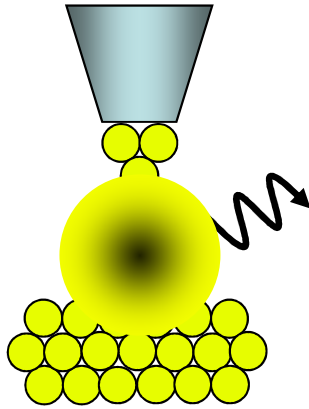

Photon counting regime

How much light ?

Best theoretical yields : 10^{-4} photon / electron

For 1nA => 10^5 emitted photons / second

Photon counting regime

Collection of the light

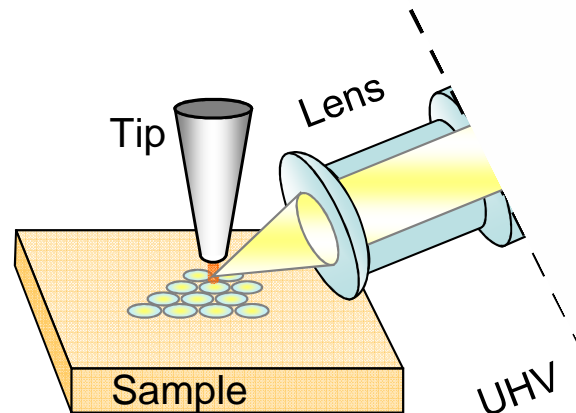

Collection of the light: Different experimental conditions

Air, and liquid-solid interfaces

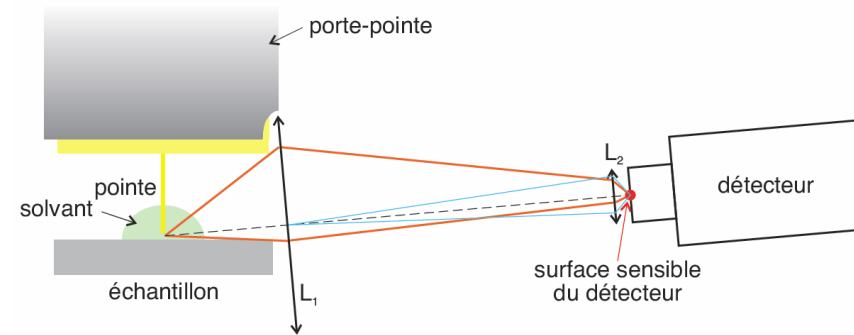

K. Perronet, Phd thesis

UHV Room temperature

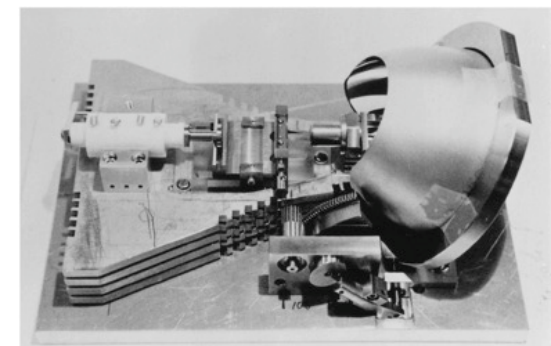
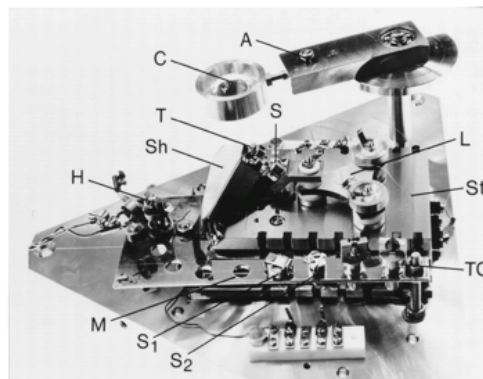

R. Berndt, Phd thesis

Collection of the light: Different experimental conditions

UHV - Low temperature

“Tube setup”

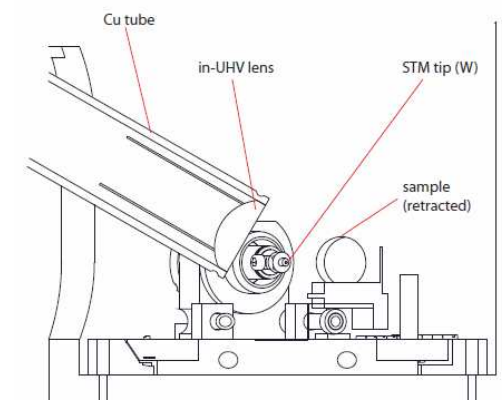
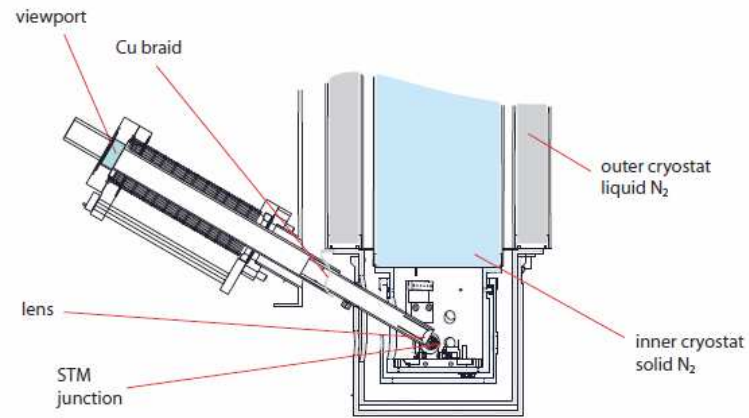

F. Rossel, Phd thesis

“Fixed lens setup”

Commercially available (Omicron)

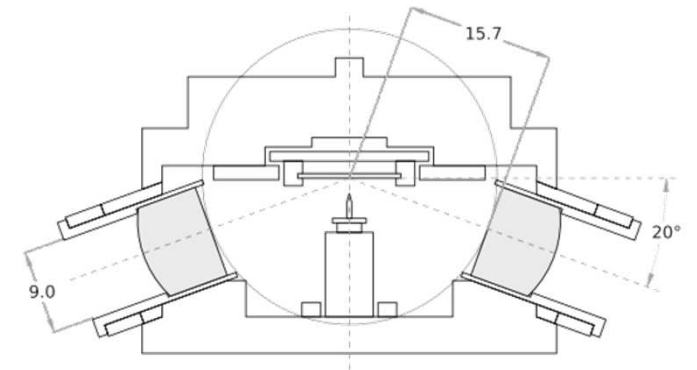
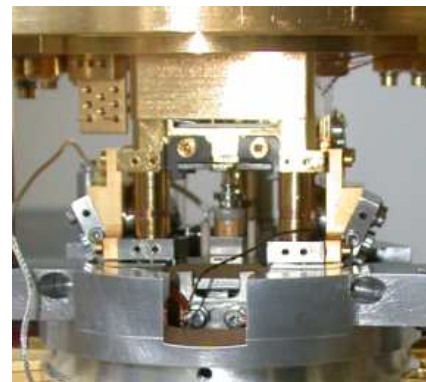

J. G. Keizer *et al.*, Rev. Sci. Instrum. 80, 123704, 2009

Collection of the light: Different experimental conditions

UHV - Low temperature

“Movable lens setup”

Commercially available (Unisoku)

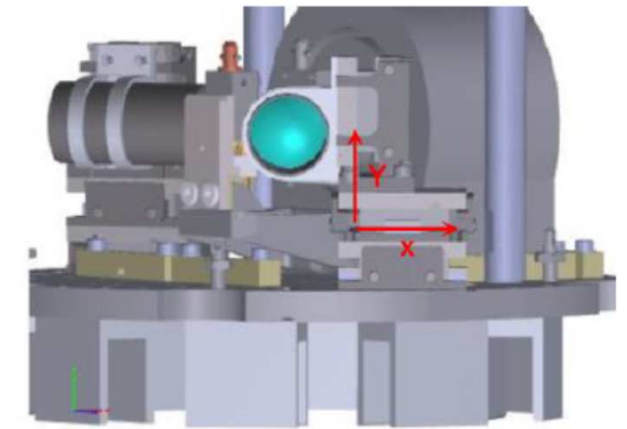
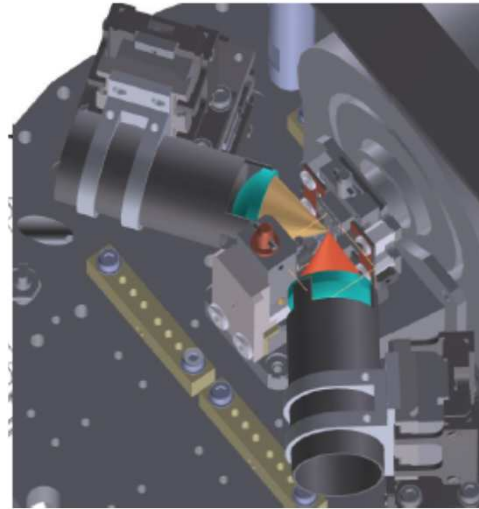

Y. Zhang *et al.*, Nature 531, 623 (2016)

“Integrated tip-mirror setup”

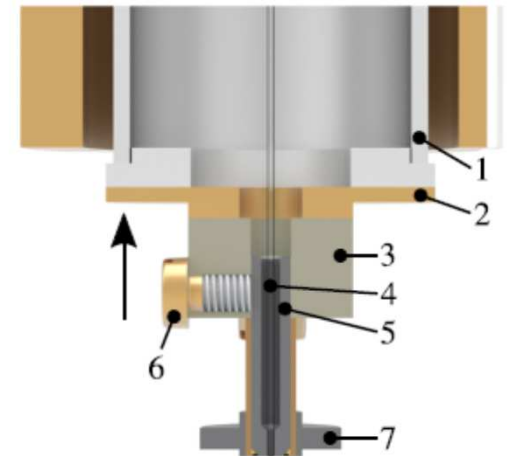
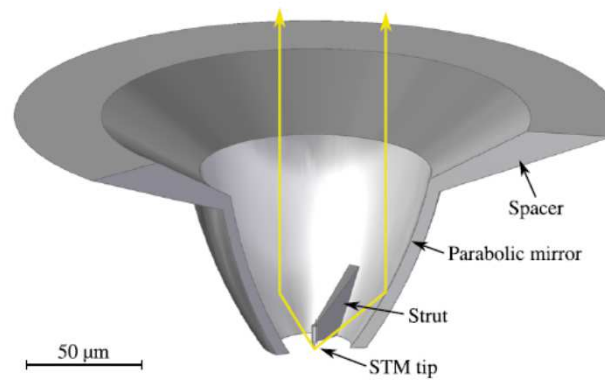

K. Edelmann *et al.*, Rev. Sci. Inst 89, 123107 (2018)

STM-induced light emission

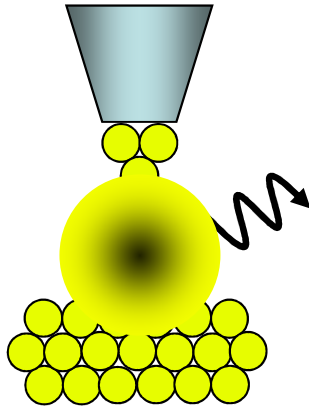

How much light ?

Best theoretical yields : 10^{-4} photon / electron

For 1nA => 10^5 emitted photons / second

Photon counting regime

Collection of the light

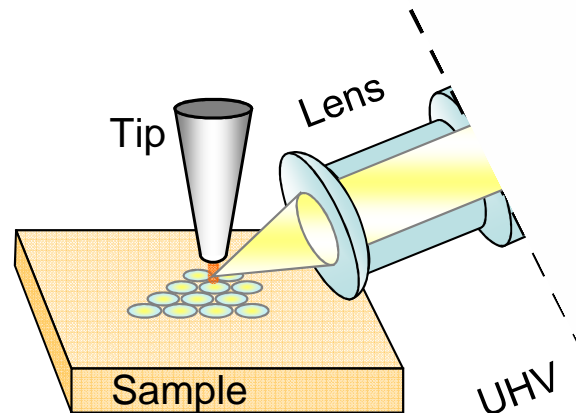

STM-induced light emission

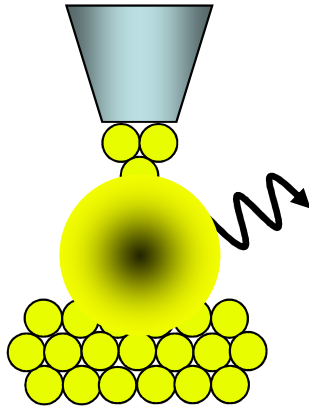

How much light ?

Best theoretical yields : 10^{-4} photon / electron

For 1nA => 10^5 emitted photons / second

Photon counting regime

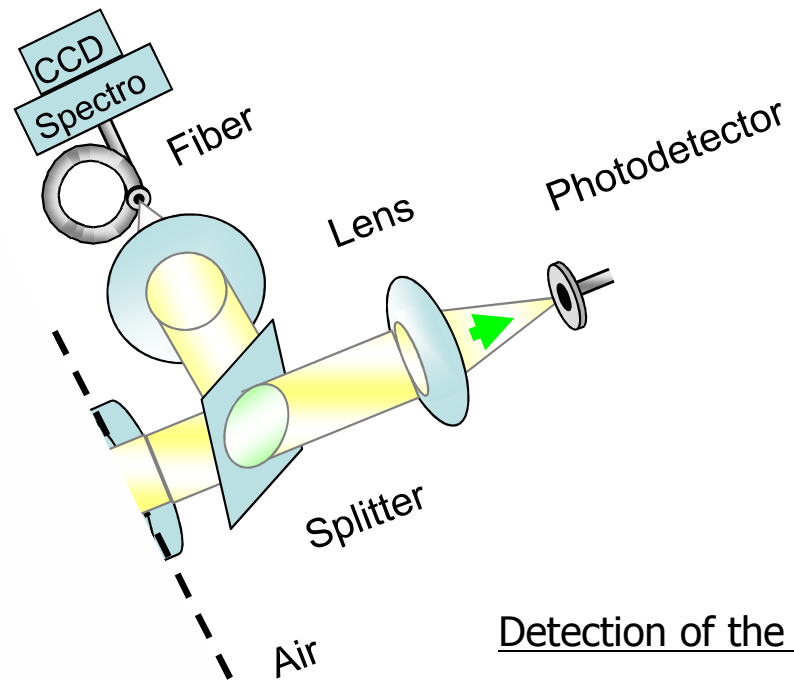

Detection of the light

Detection of the light:

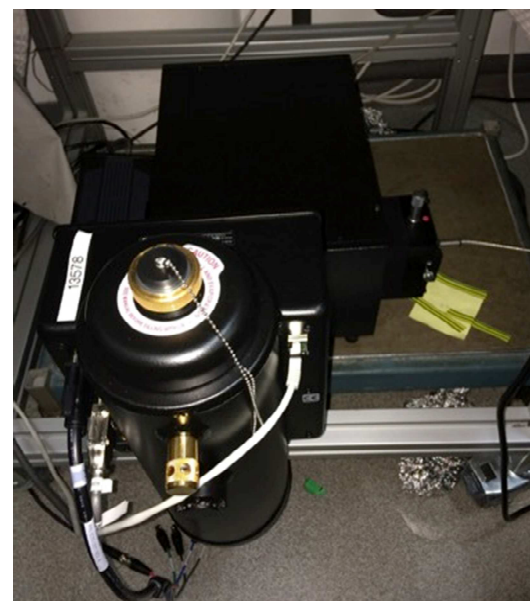
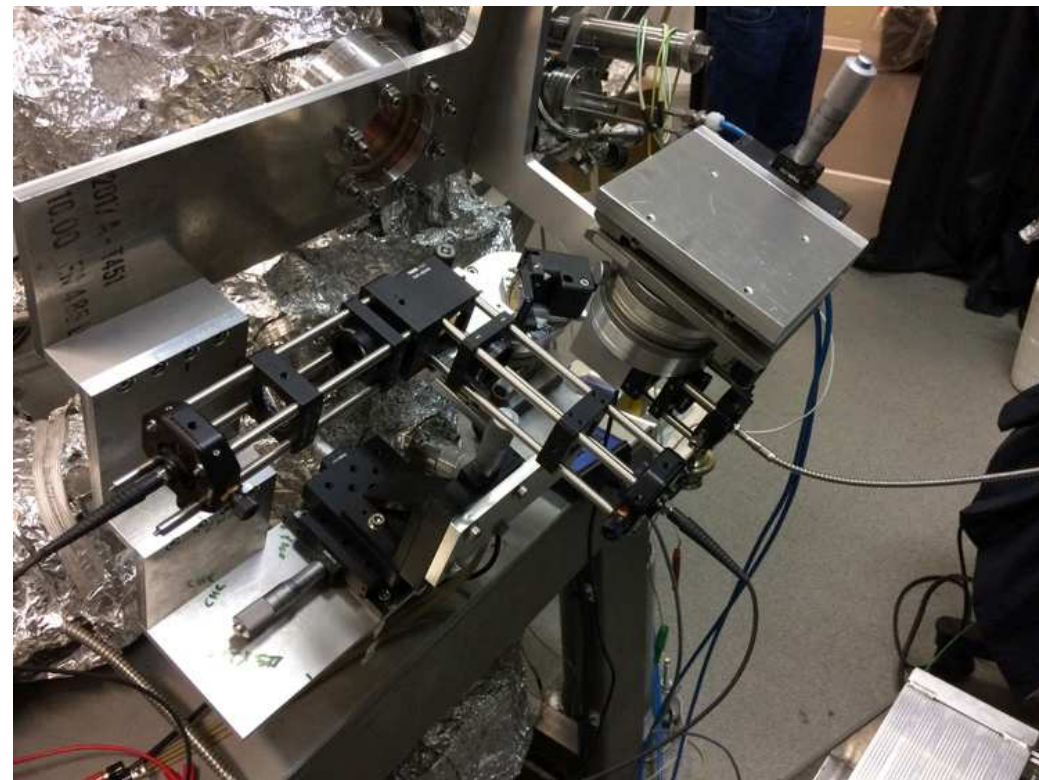
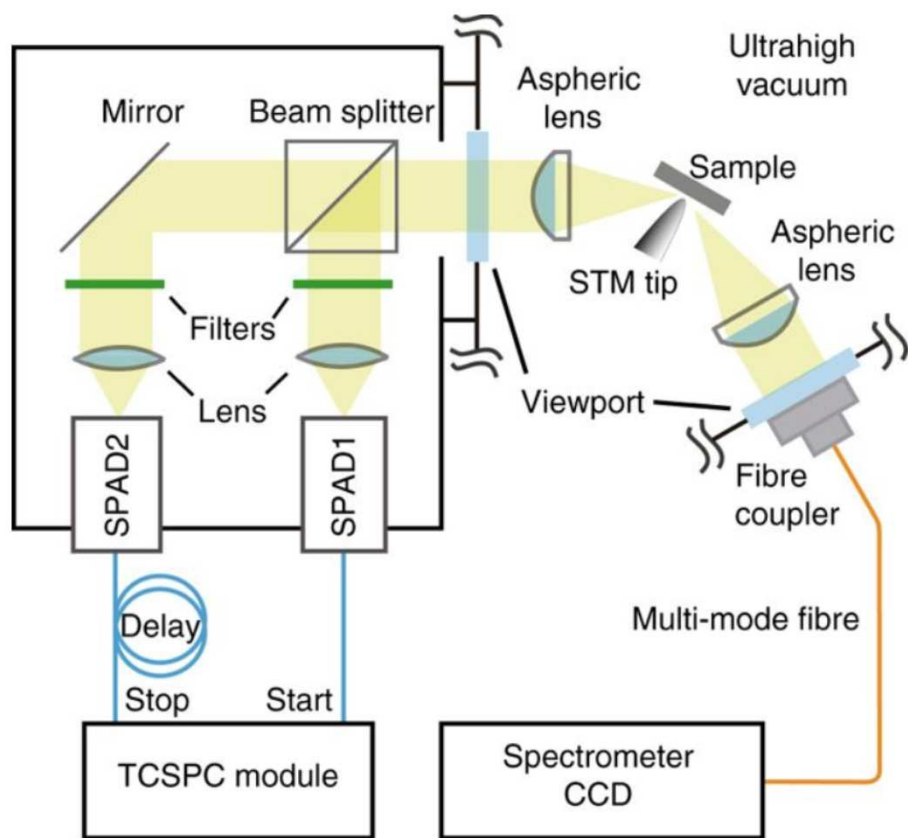

L. Zhang *et al.*, Nat. Comm. 8, 580 (2017)

Detection of the light:

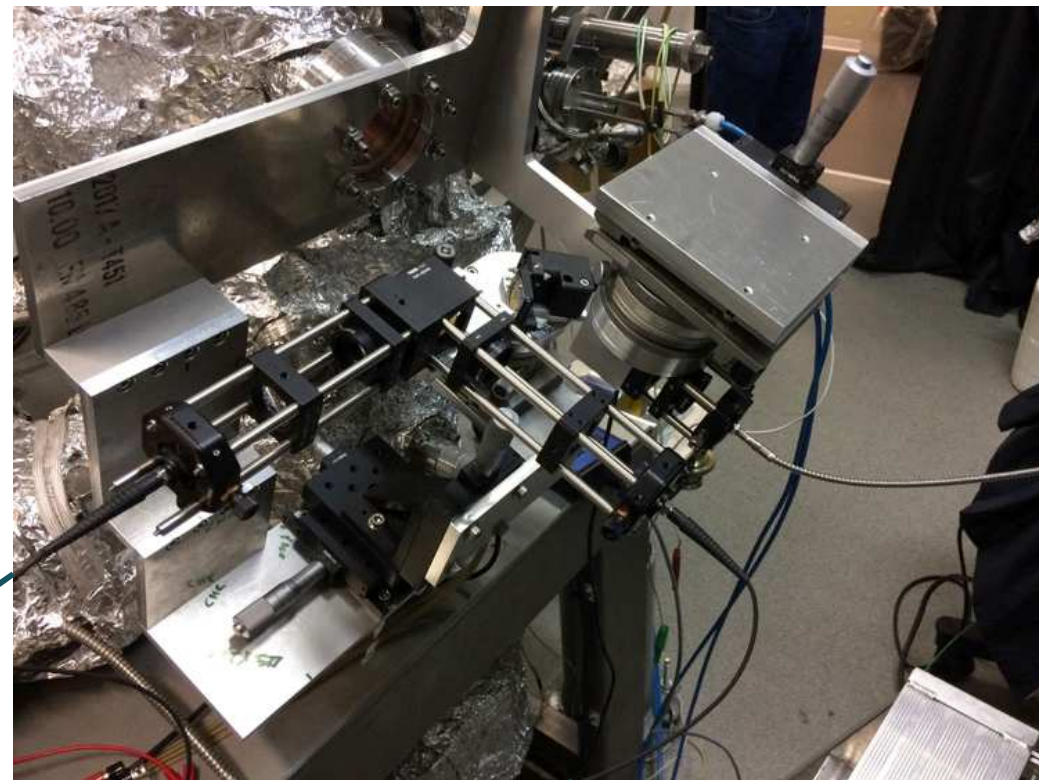
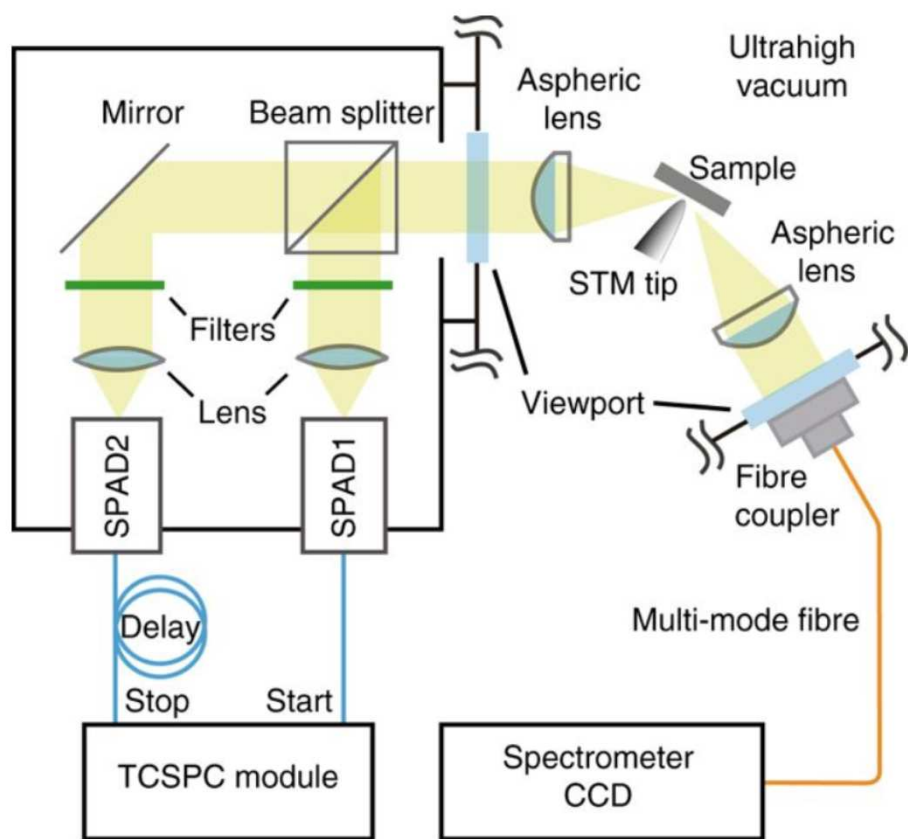

L. Zhang *et al.*, Nat. Comm. 8, 580 (2017)

Single-molecule fluorescence with STM:

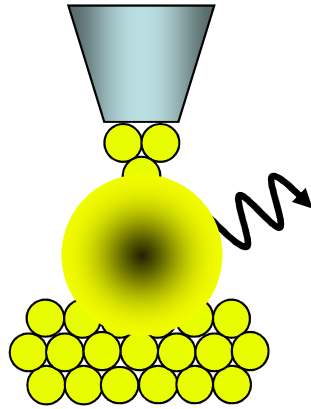

General idea

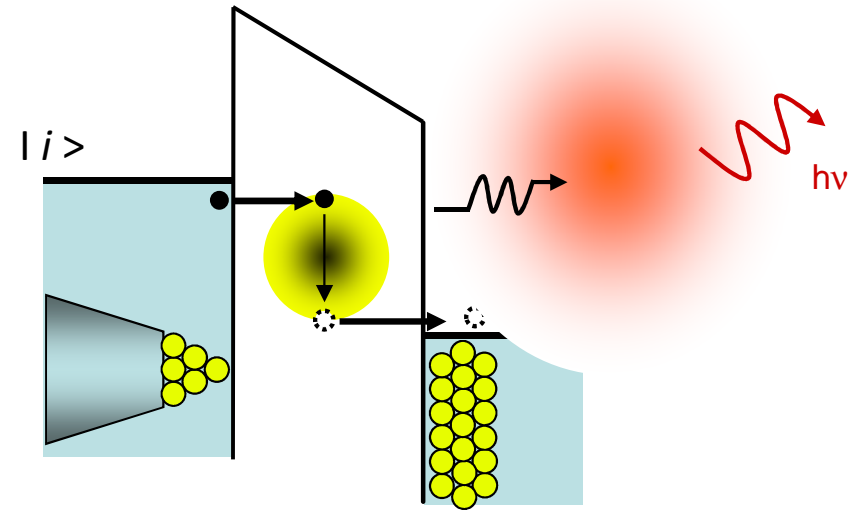

- **Photons are emitted by inelastic electrons**
- **Amplification by localized surface plasmons**

Single-molecule fluorescence with STM:

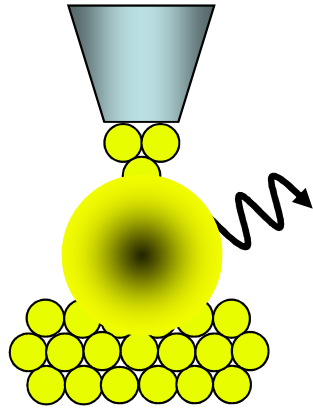

General idea

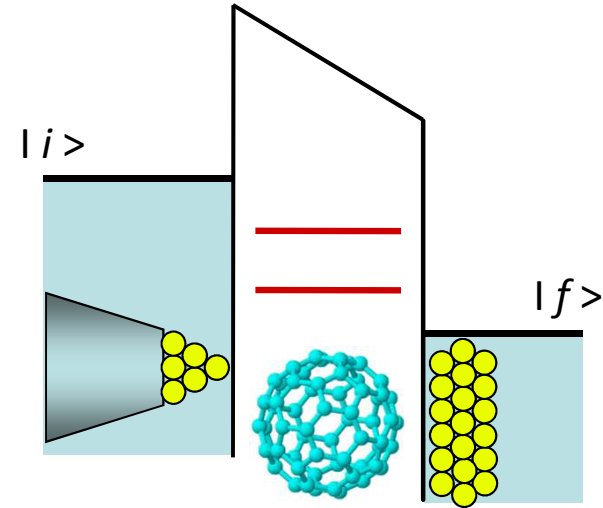

- **Photons are emitted by inelastic electrons**
- **Amplification by localized surface plasmons**

Single-molecule fluorescence with STM:

General idea

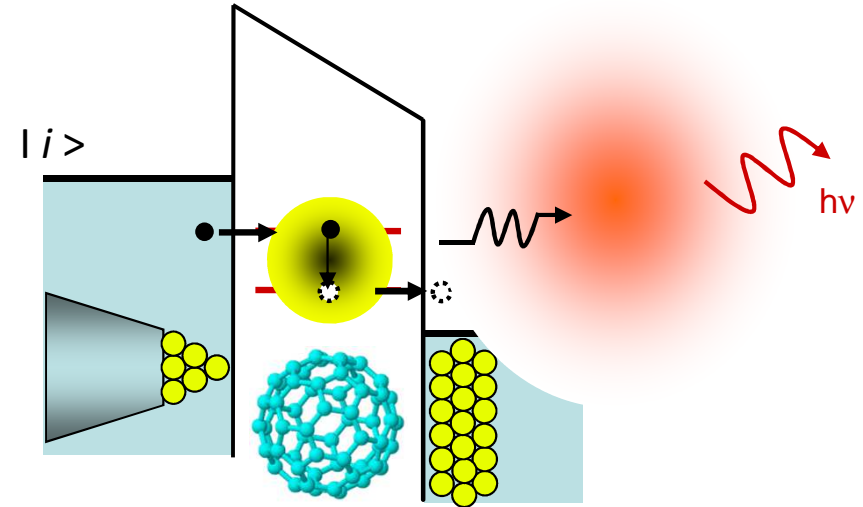
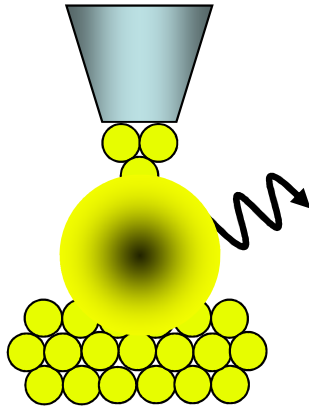

- Photons are emitted by inelastic electrons
- Amplification by localized surface plasmons

Single molecule fluorescence ?

Single-molecule fluorescence with STM: General idea

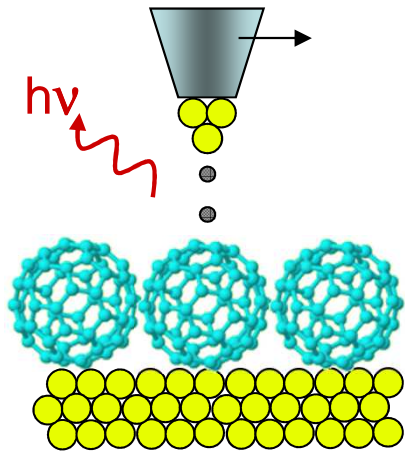

R. Berndt *et al. Science* 262, 1425 (1993)

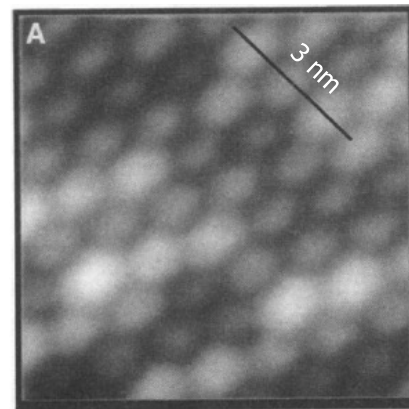

STM topography

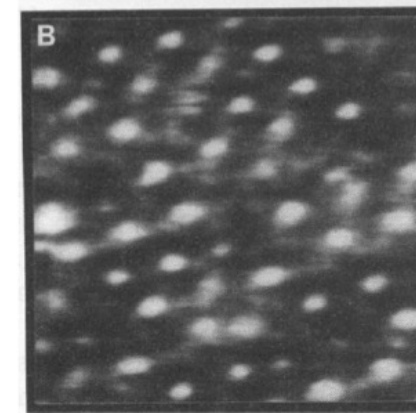

Photon map

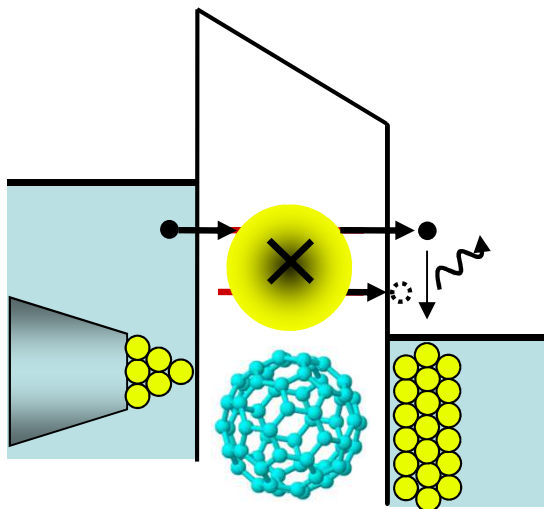

Quenching of the fluorescence !

Single-molecule fluorescence with STM: General idea

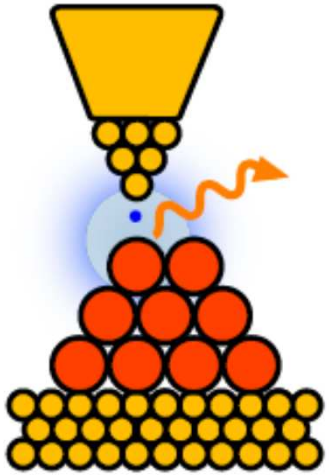

Multilayers of molecules

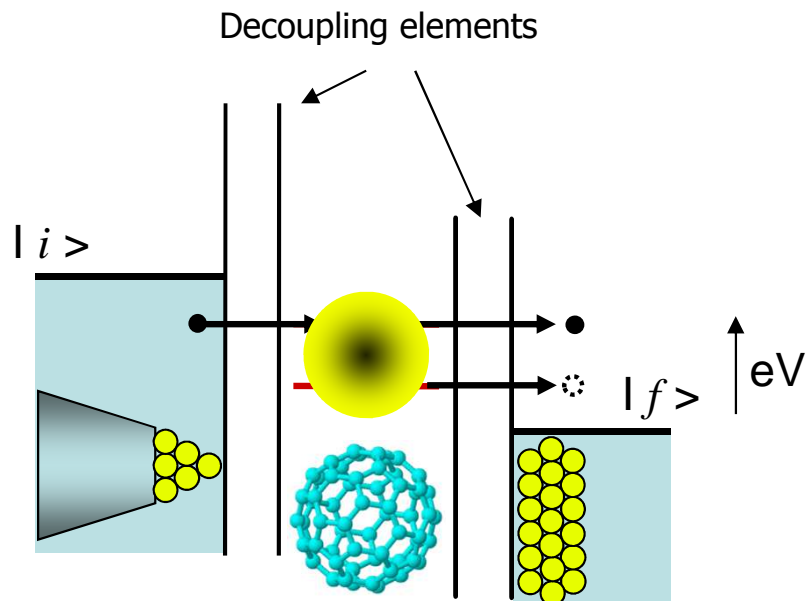

Single-molecule fluorescence with STM:

Multilayers of molecules

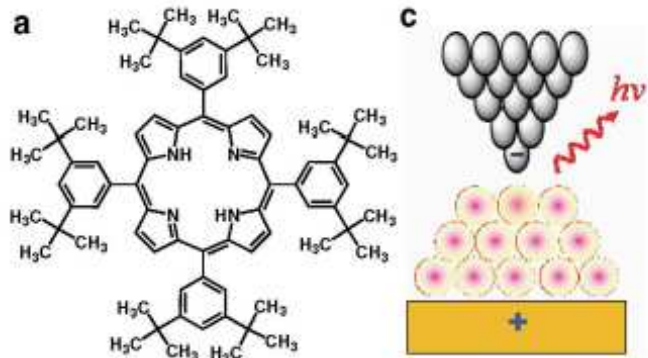

Z.-C. Dong *et al.*
Phys. Rev. Lett. 92, 086801 (2004)

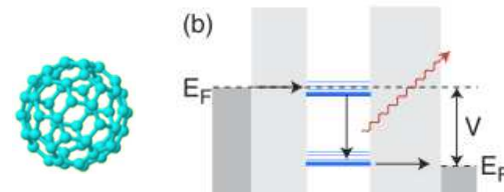
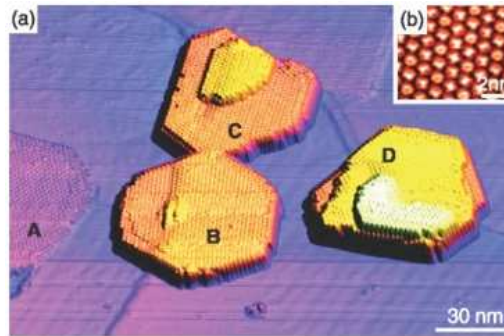

E. Cavar *et al.*
Phys. Rev. Lett. 95, 196102 (2005)

P. Merino *et al.*
Nature Commun. 6, 8461 (2015)

C. Grosse *et al.*
ACS Nano 11, 1230 (2017)

A. Rosłowska *et al.*
Nano Lett 18, 4001 (2018)

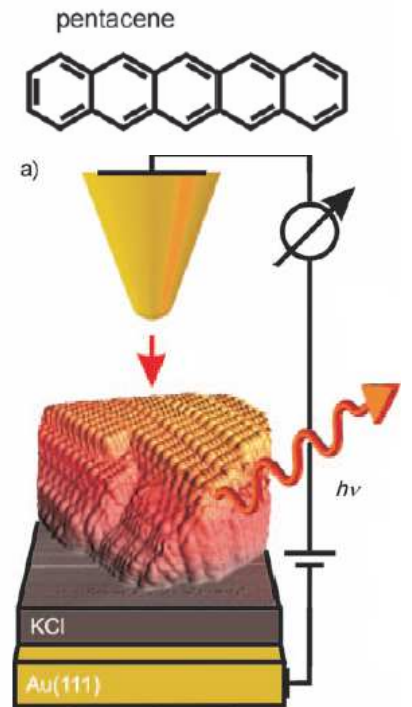
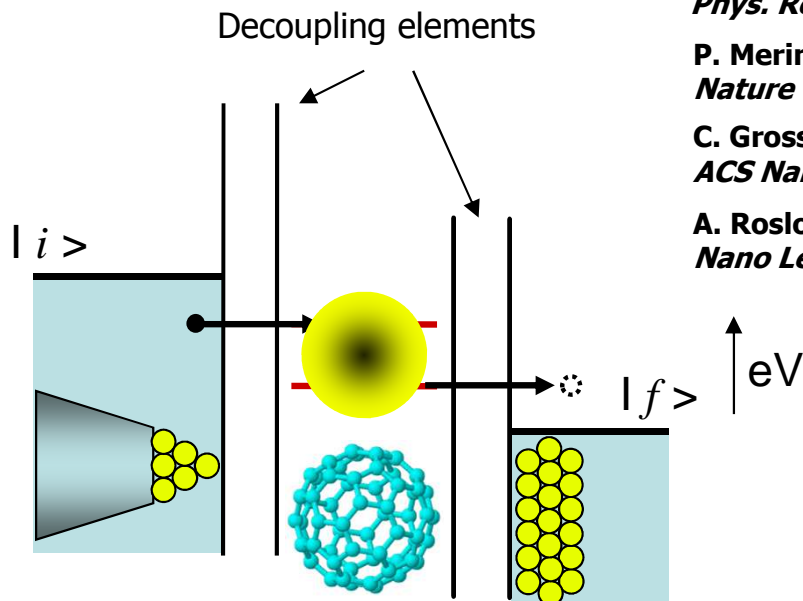

A. Kabakchiev *et al.*
ChemPhysChem 11, 3412 (2010)

Not single molecule !

Single-molecule fluorescence with STM: Multilayers of molecules

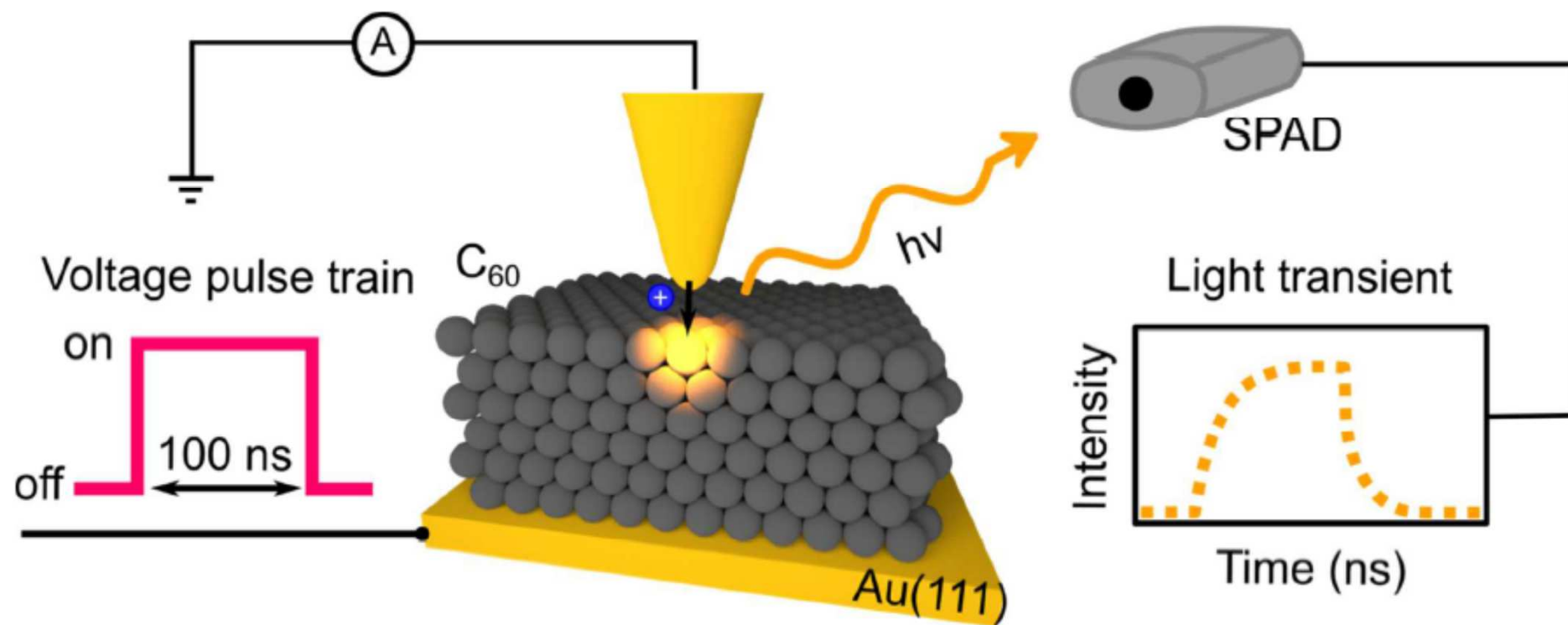

Probing single charge and exciton dynamics

A. Rosłowska *et al.* *Nano Lett* 18, 4001 (2018)

Single-molecule fluorescence with STM

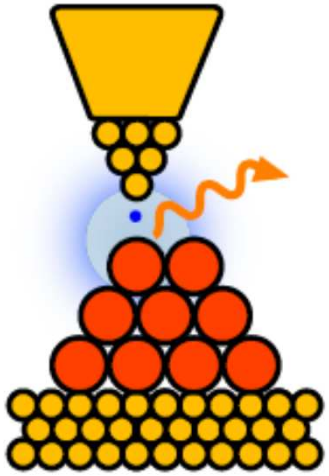

Multilayers of molecules

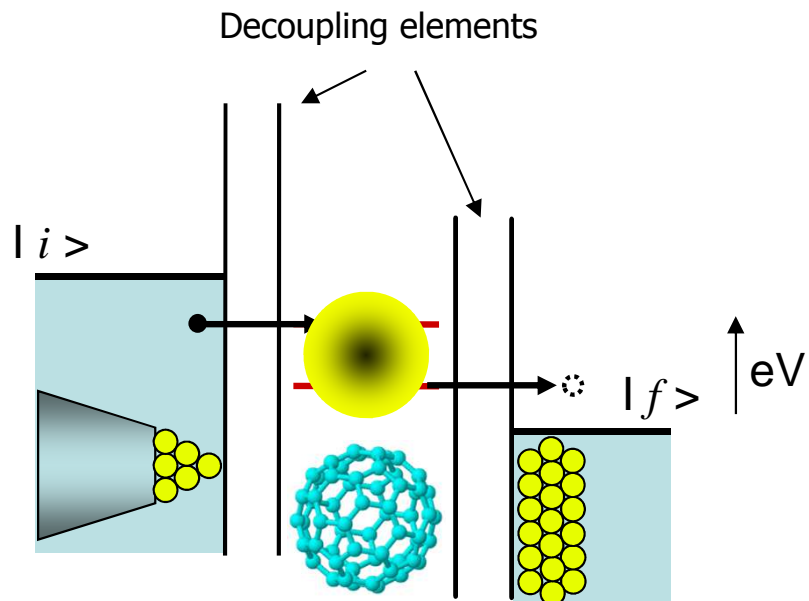

Single-molecule fluorescence with STM

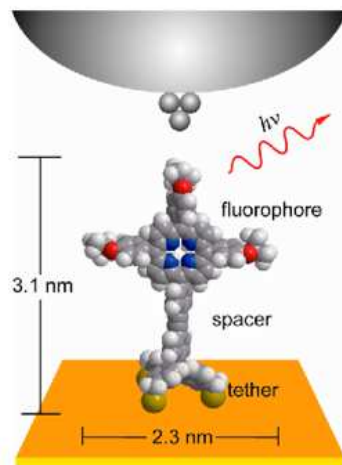

Self-decoupled molecules

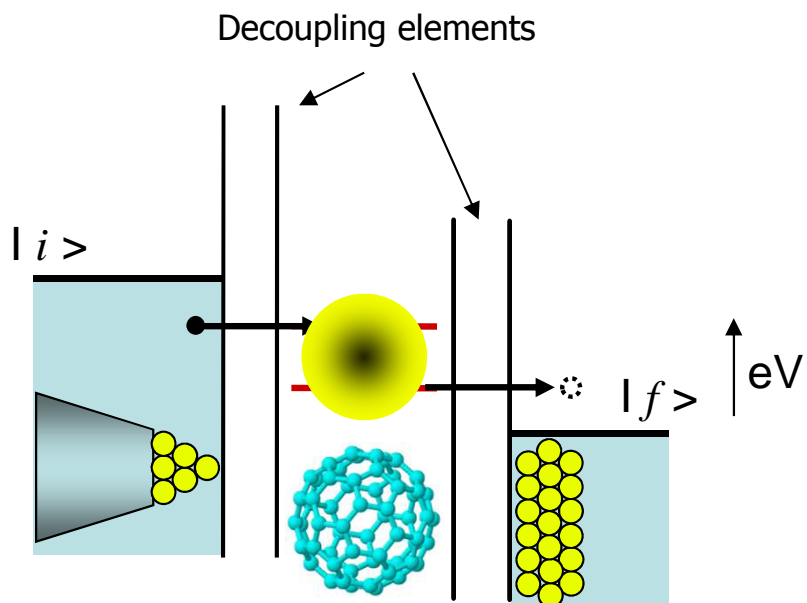

Single-molecule fluorescence with STM: Self-decoupled molecules

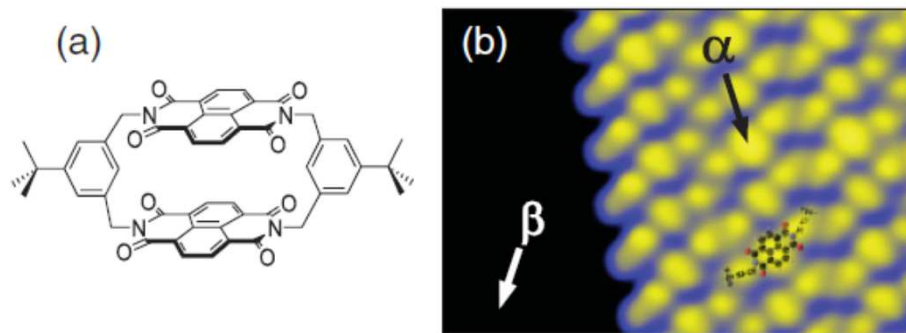

N. L. Schneider *et al.*
PRB 84, 153403 (2011)

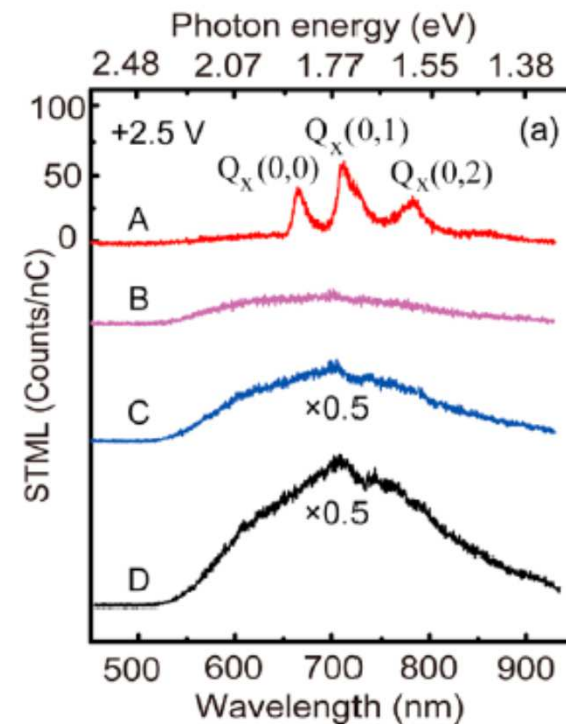
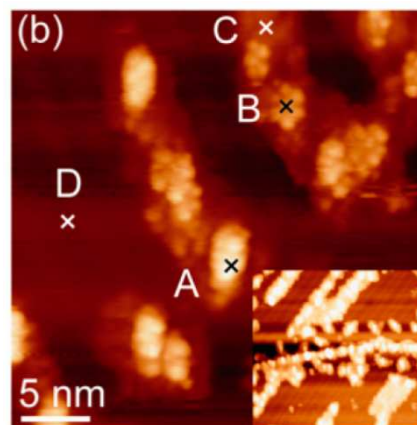
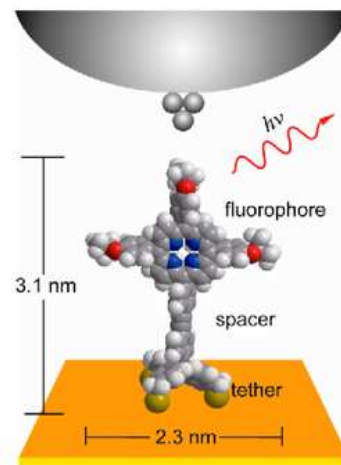
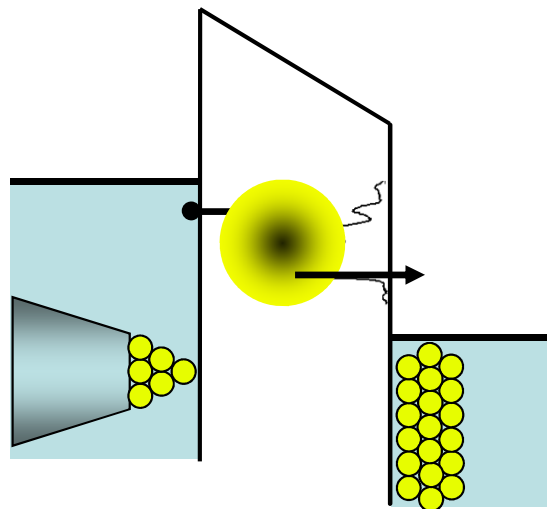

S.-E. Zhu *et al.*
JACS 135, 15794 (2013)

Single-molecule fluorescence with STM

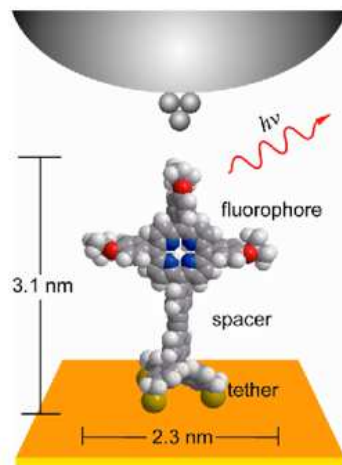

Self-decoupled molecules

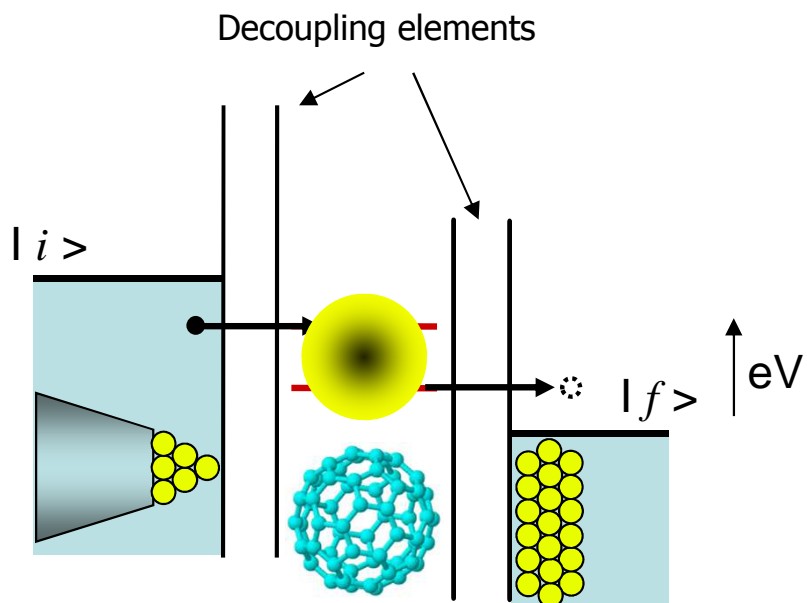

Single-molecule fluorescence with STM

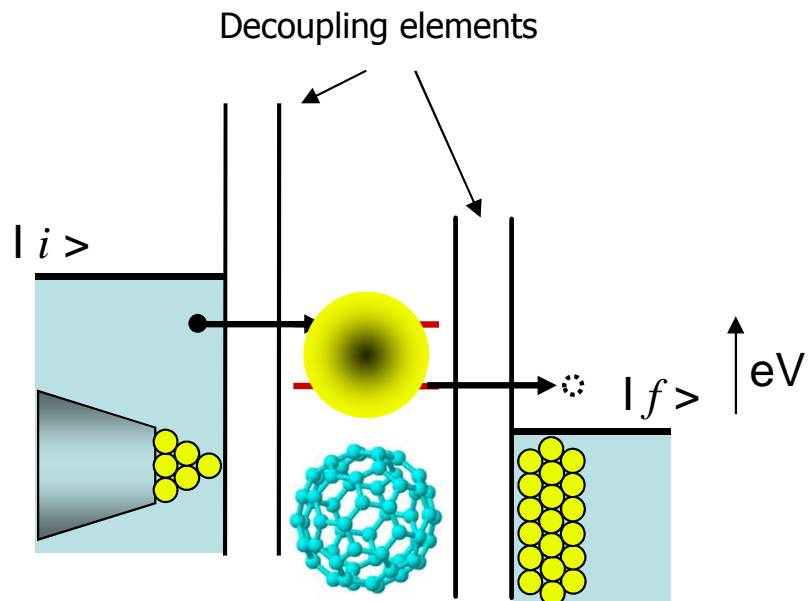
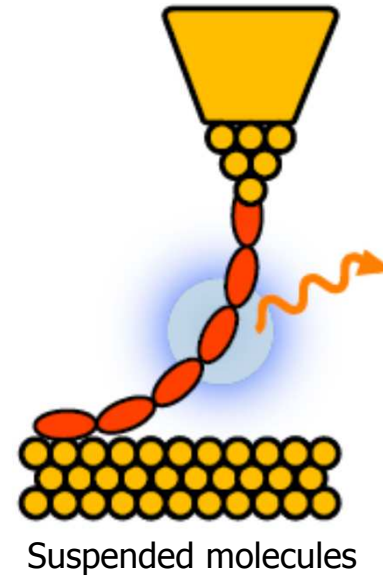

Single-molecule fluorescence with STM:

Suspended molecules

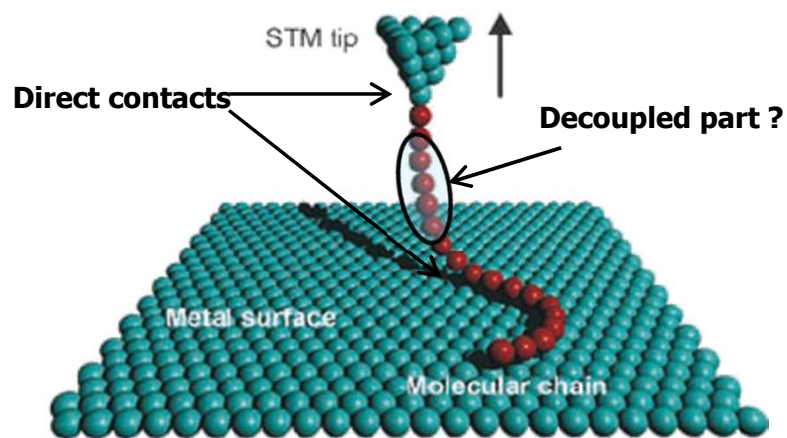

L. Lafferentz *et al.*, *Science* 323, 1193 (2009)

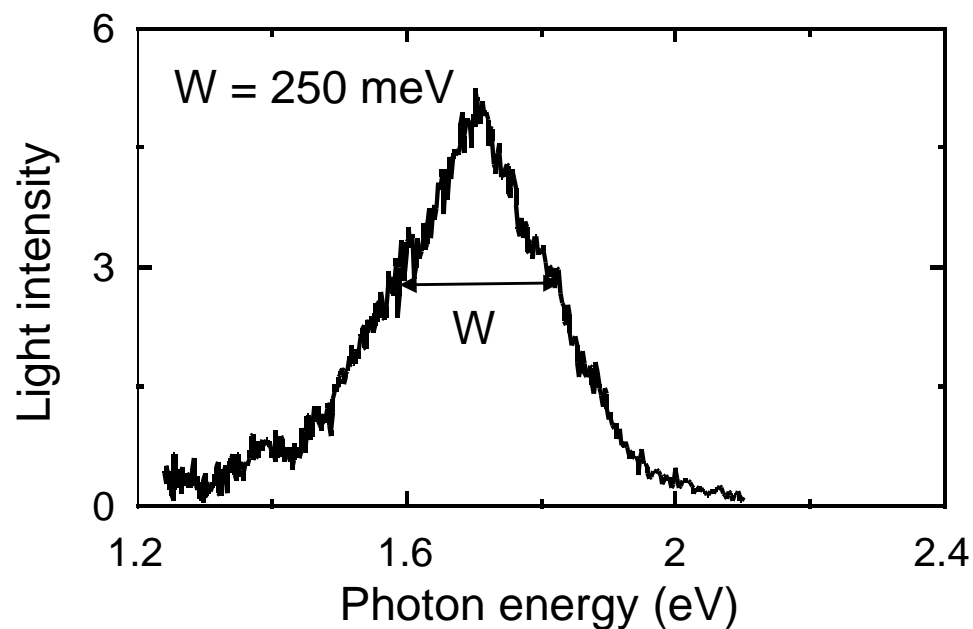
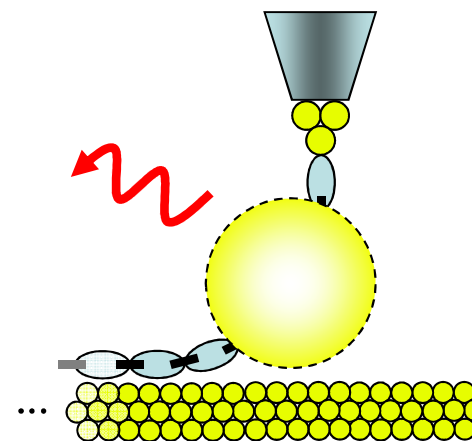
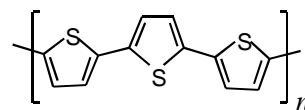

- Single-molecule fluorescence (?)
- Behaves like a LED

Reecht *et al.* *Phys. Rev. Lett.* 112, 047403 (2014)

Single-molecule fluorescence with STM: Suspended molecules

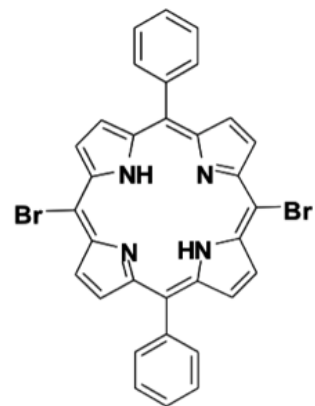
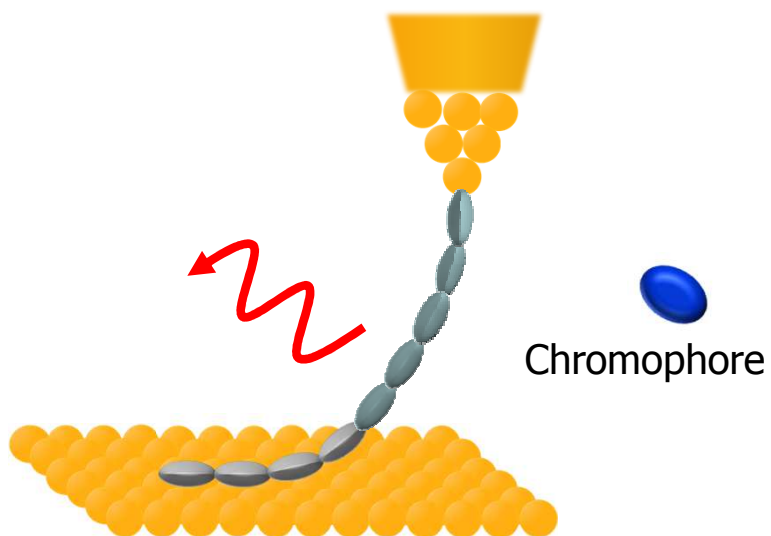

+

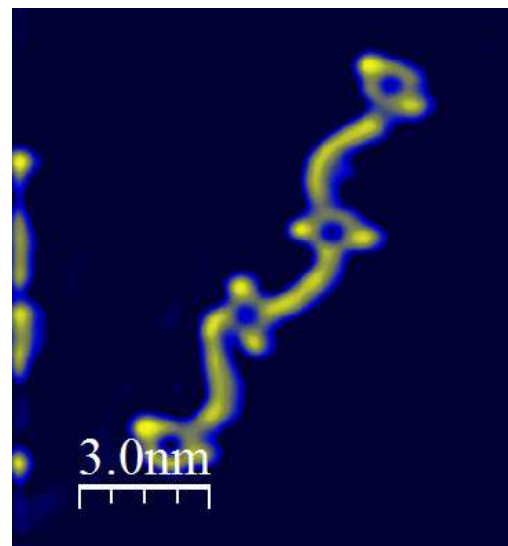
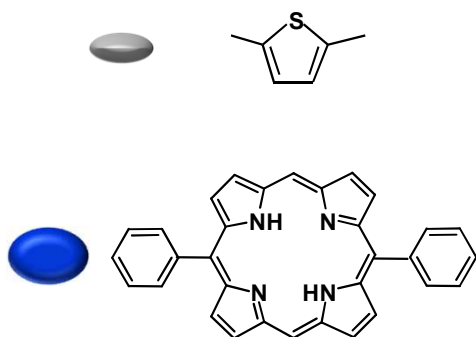
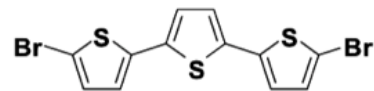

Single-molecule fluorescence with STM: Suspended molecules

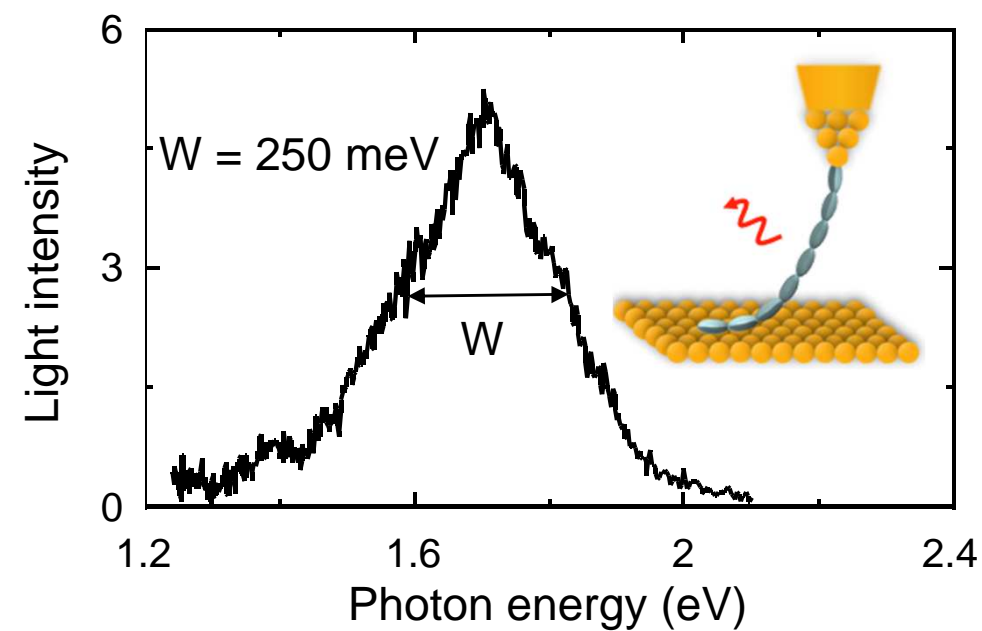
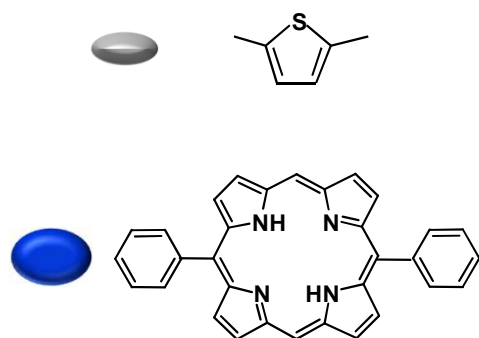
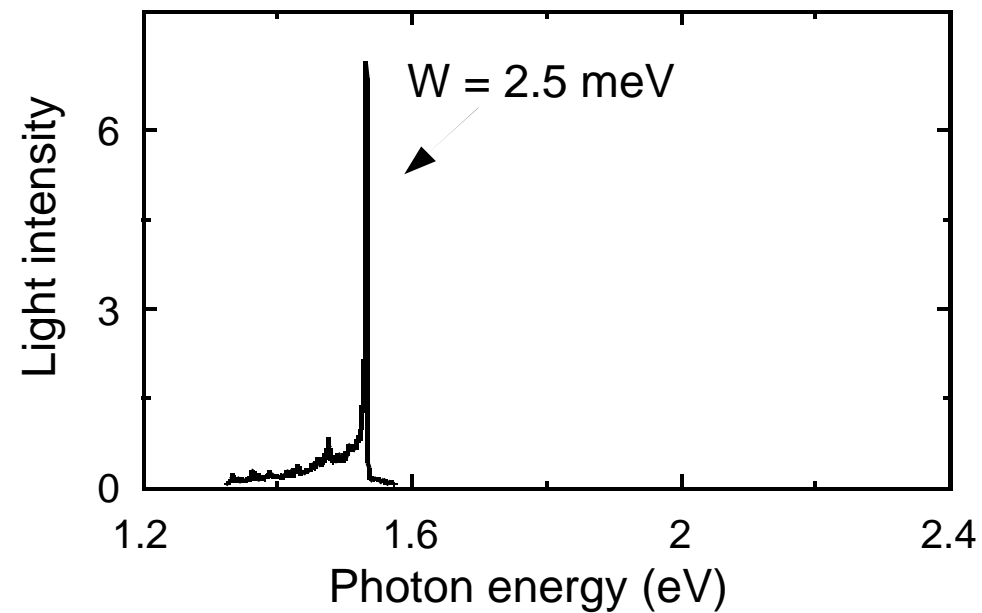
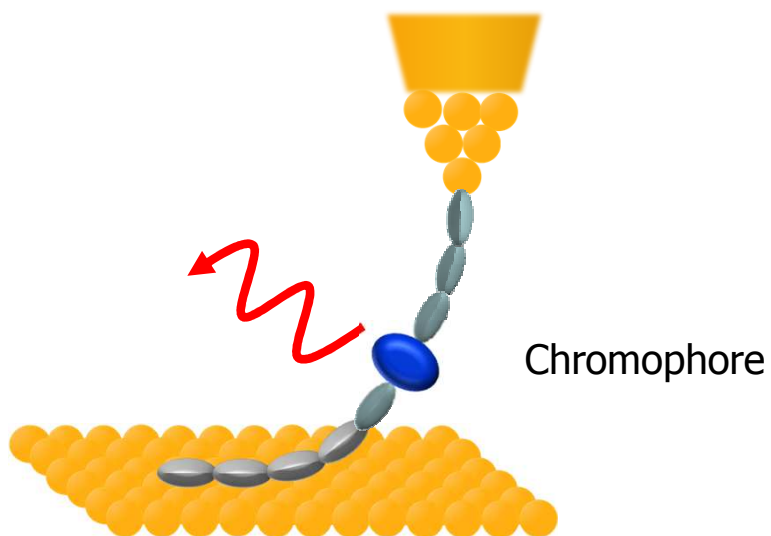

Single-molecule fluorescence with STM: Suspended molecules

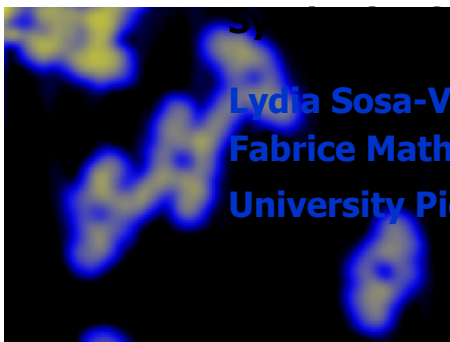
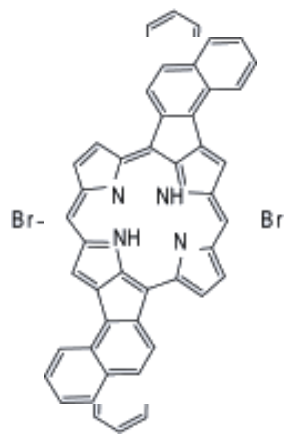

the porphyrin p
 Lydia Sosa-Vargas
 Fabrice Mathevet
 University Pierre et Marie Curie
 $h\nu_{\text{exp}} = 1.28$ eV

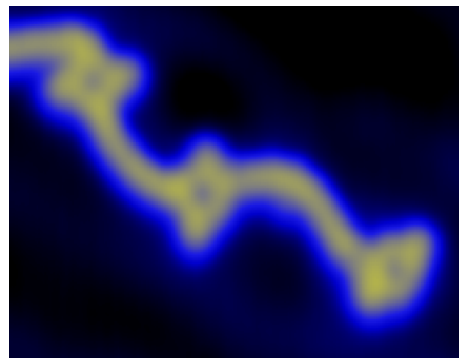
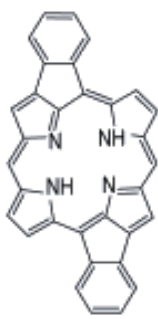
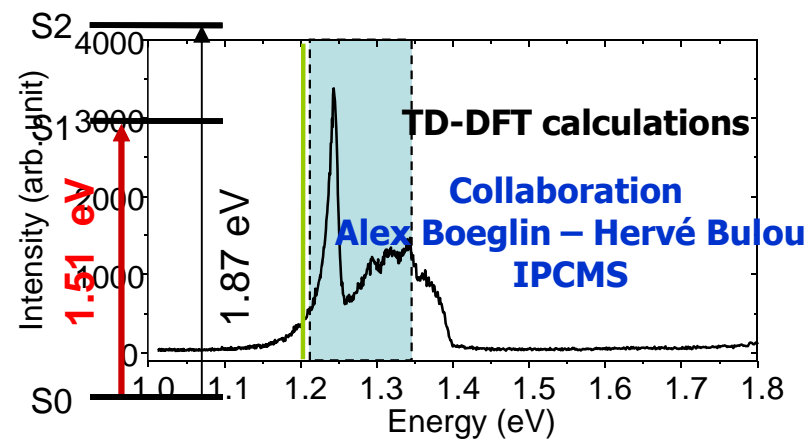
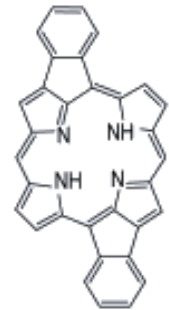

$h\nu_{\text{exp}} = 1.50 \pm 0.04$ eV

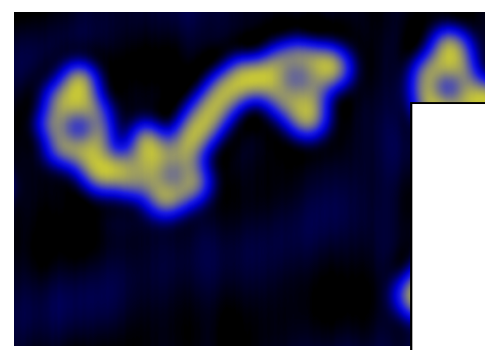
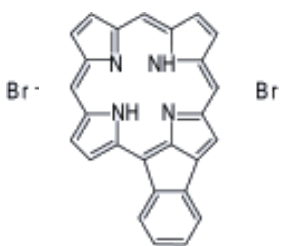
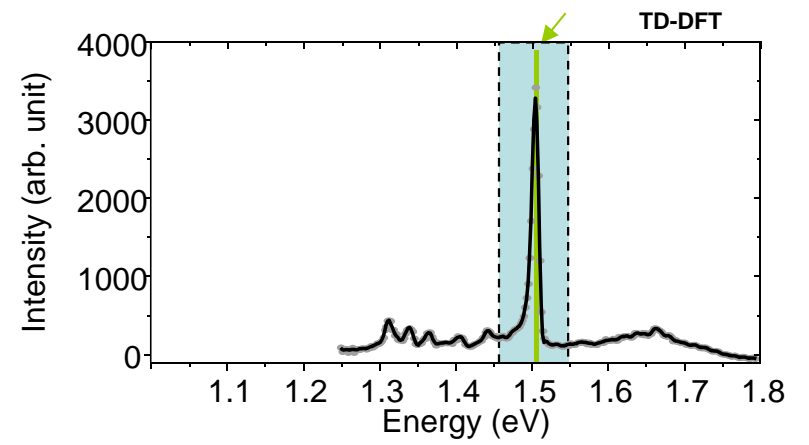

Fluorescence of the molecule !
 Controlling the emission color

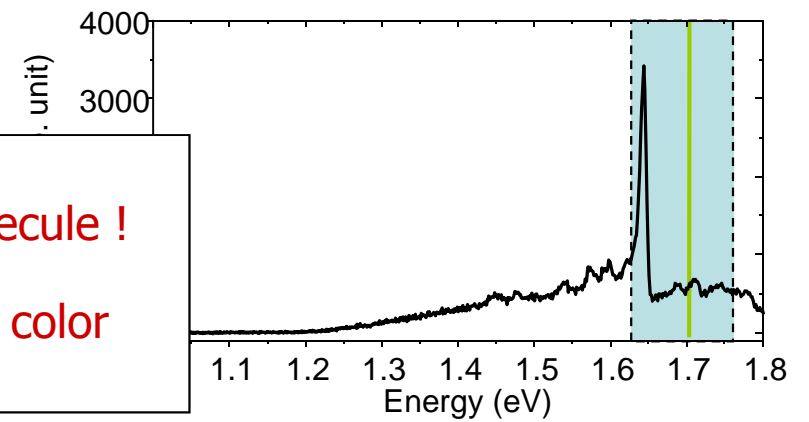

Single-molecule fluorescence with STM: Suspended molecules

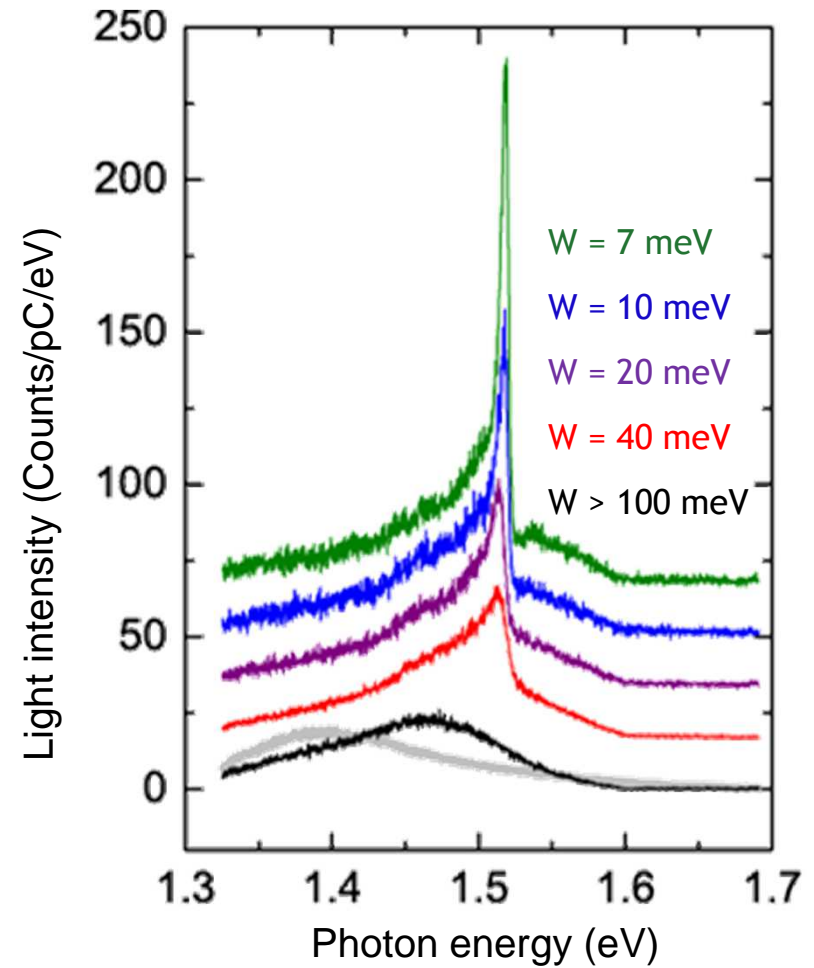
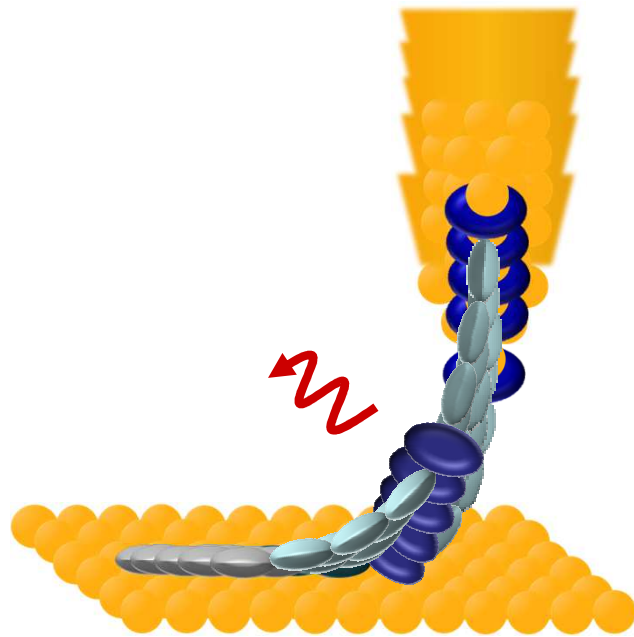

Progressive decoupling of the molecular emitter

Controlling the emission linewidth

Single-molecule fluorescence with STM: Suspended molecules

J. Cai *et al.*
Nature, 466, 470-473 (2010)

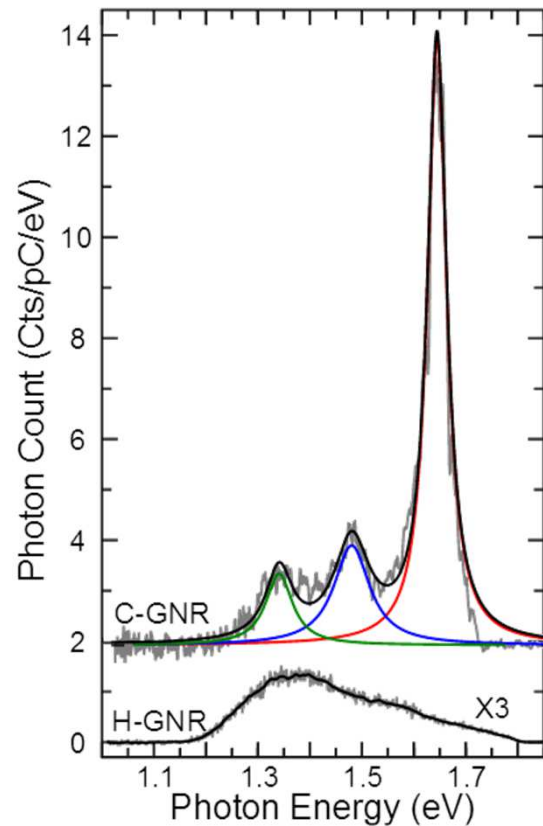
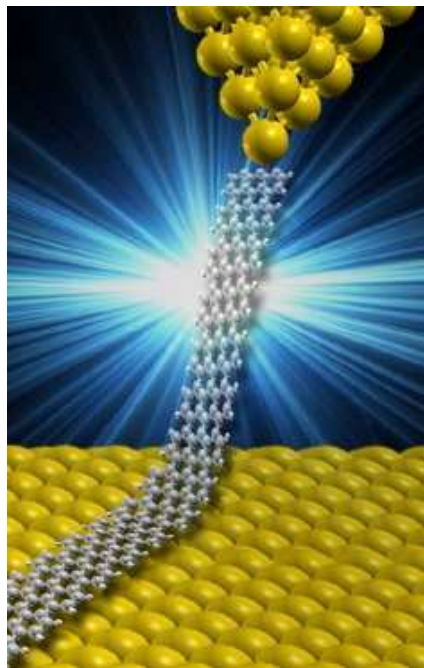
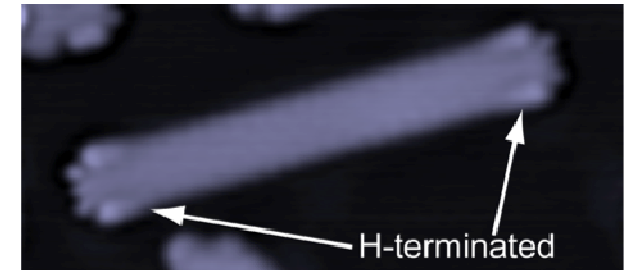
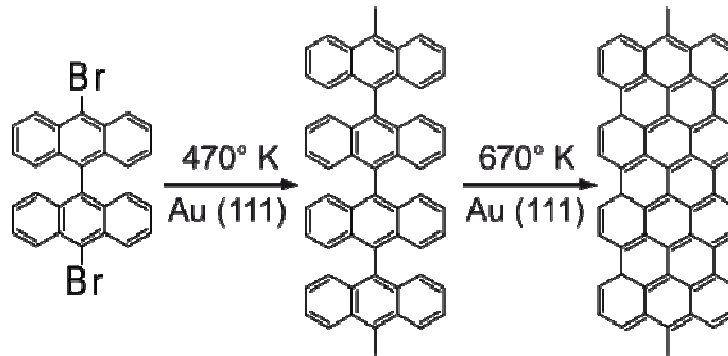

Intense light emission (x 100),
stand high currents (tens of nA)

Brilliant and robust single-molecule
optoelectronic device

M.C. Chong *et al.* *Nanoletters* 18, 175 (2018)

Single-molecule fluorescence with STM: Suspended molecules

- Narrow-line emission in contact with electrodes

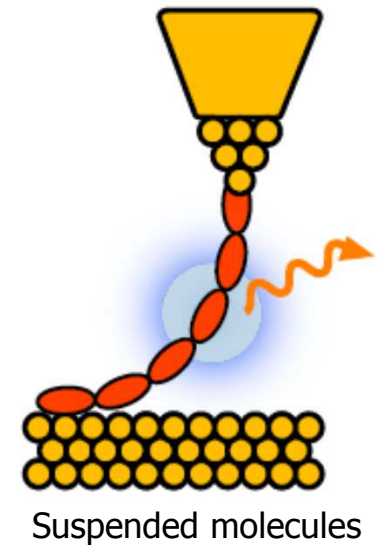
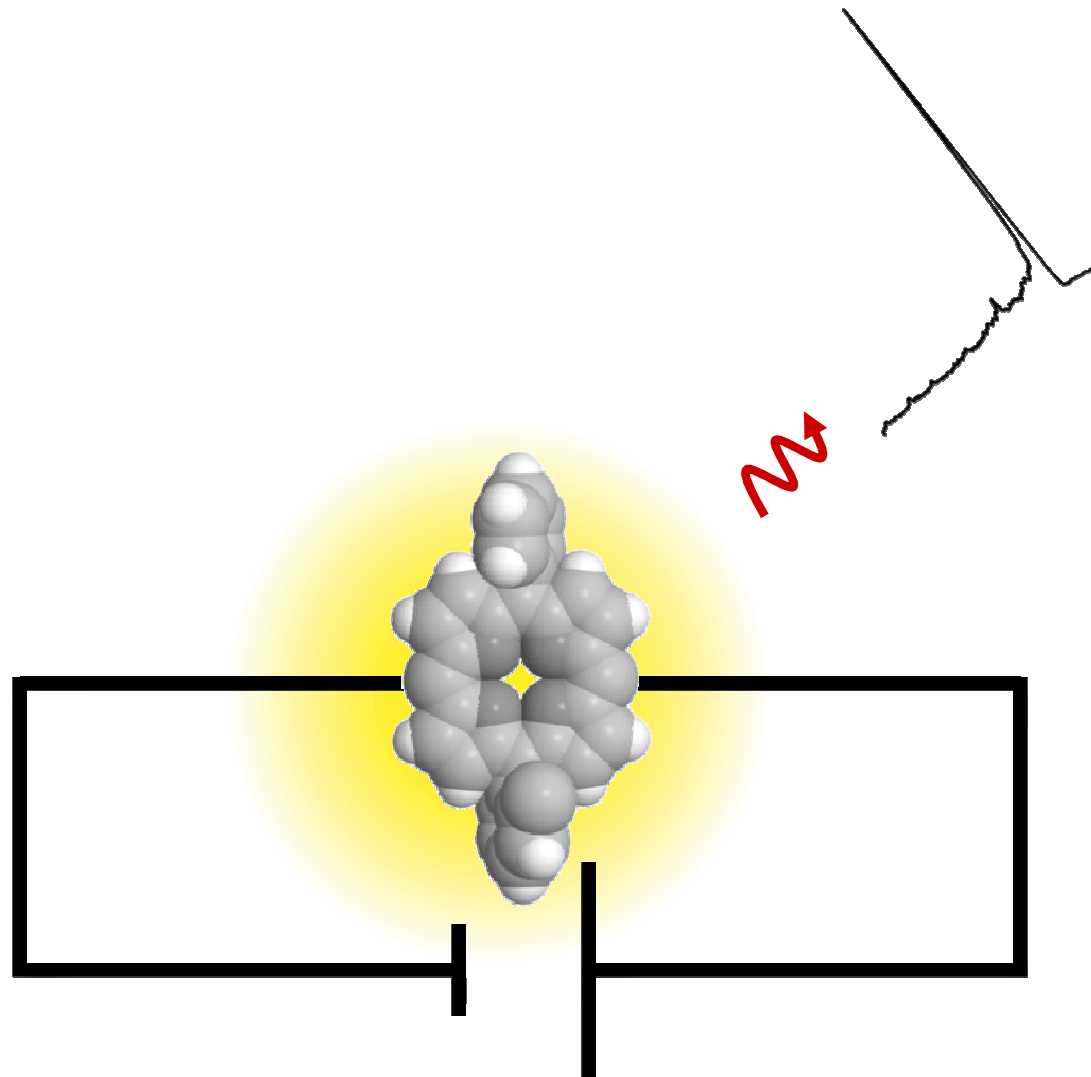

Single-molecule fluorescence with STM: Suspended molecules

- Narrow-line emission in contact with electrodes
- Control of the linewidth and the color of the emission

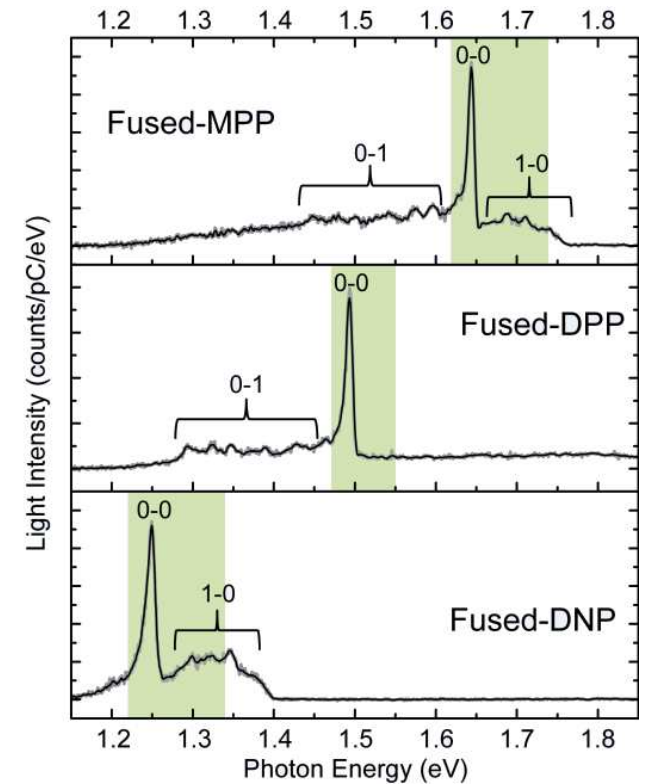
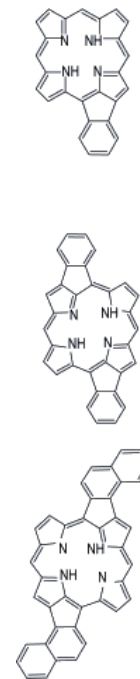
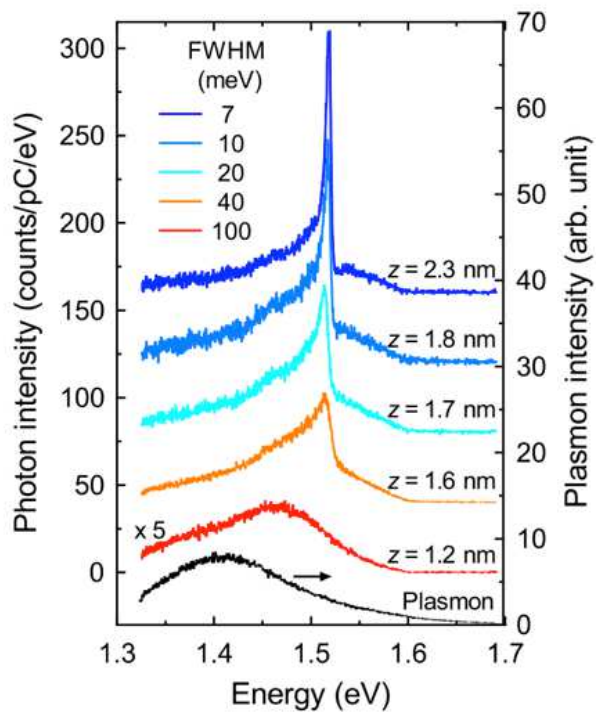
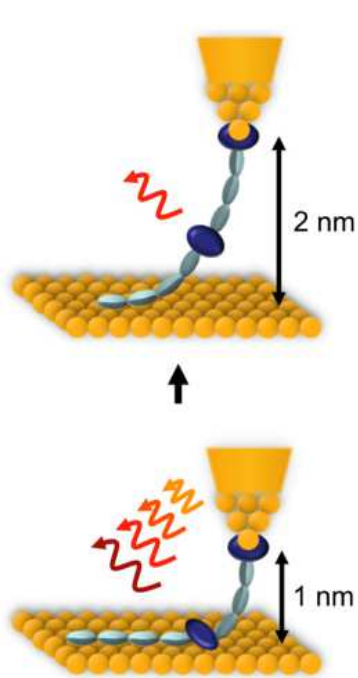
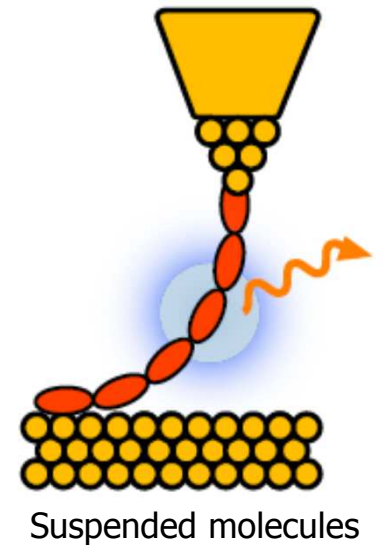

Single-molecule fluorescence with STM: Suspended molecules

- Narrow-line emission in contact with electrodes
- Control of the linewidth and the color of the emission.
- Brilliant GNR optoelectronic devices

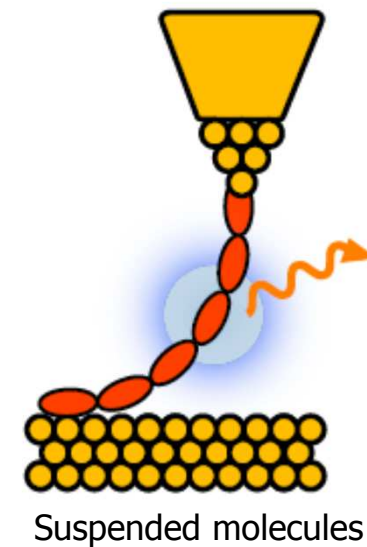
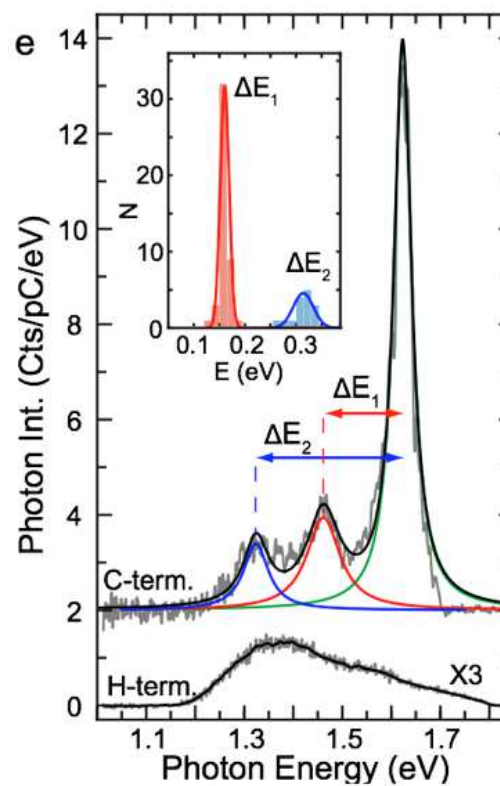
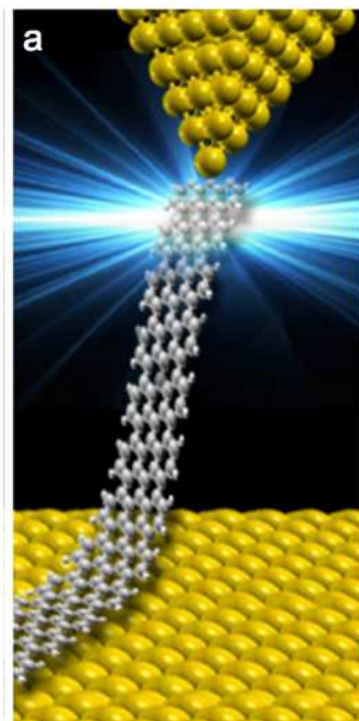

Single-molecule fluorescence with STM: Suspended molecules

- Narrow-line emission in contact with electrodes
- Control of the linewidth and the color of the emission.
- Brilliant GNR optoelectronic devices

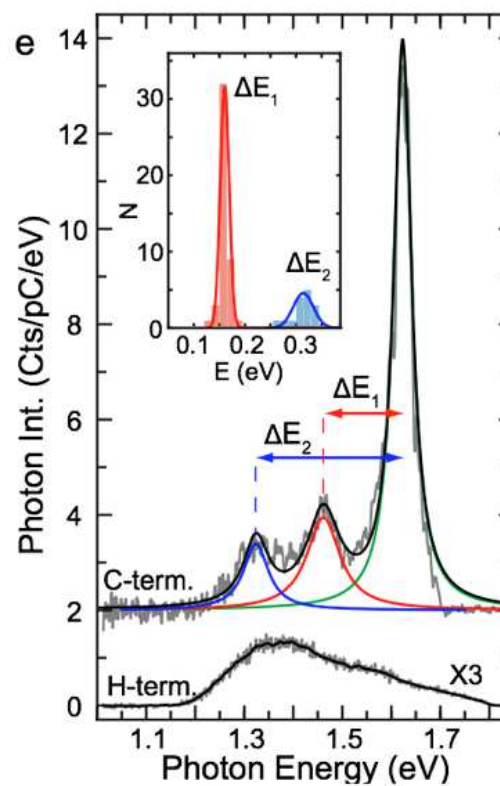
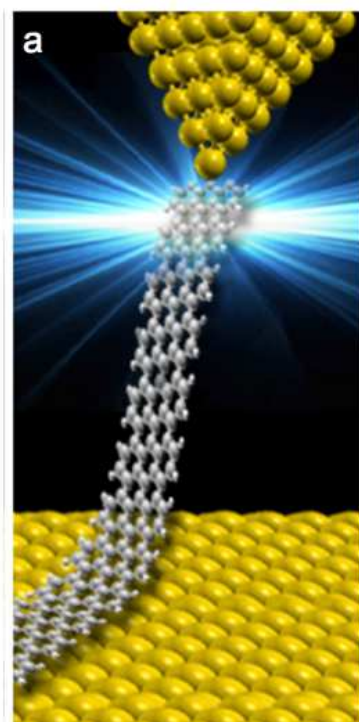
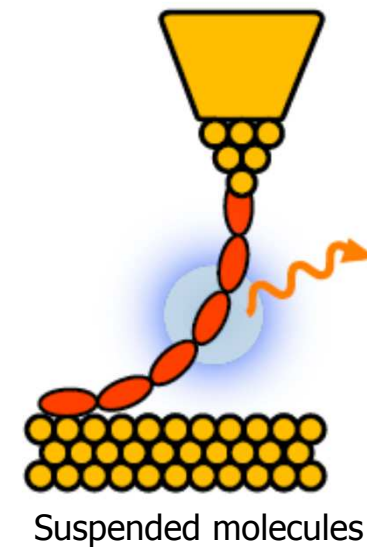

Single-molecule fluorescence ...

Single-molecule fluorescence with STM: Suspended molecules

- Narrow-line emission in contact with electrodes
- Control of the linewidth and the color of the emission.
- Brilliant GNR optoelectronic devices

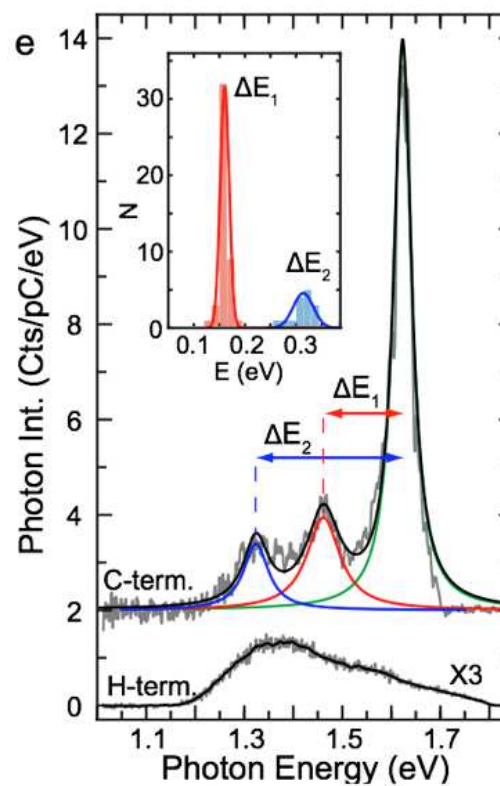
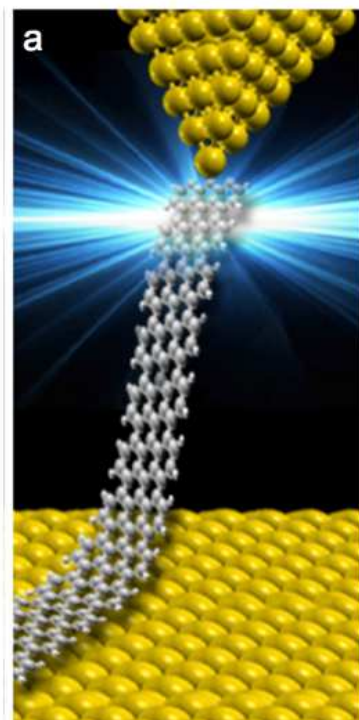
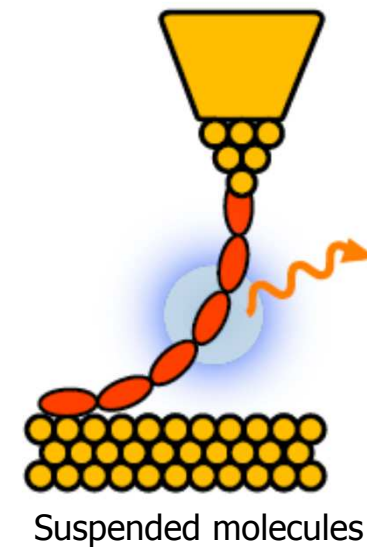

Single-molecule fluorescence no spatial resolution !

Single-molecule fluorescence with STM

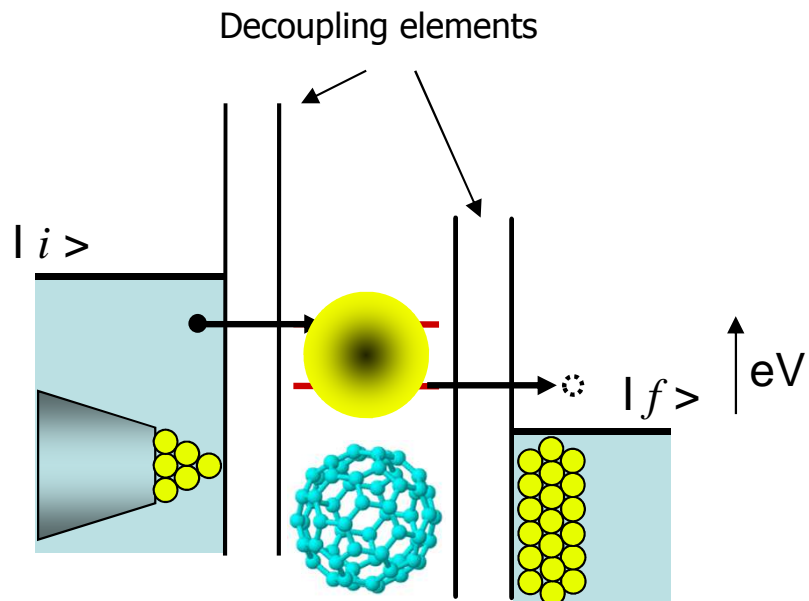
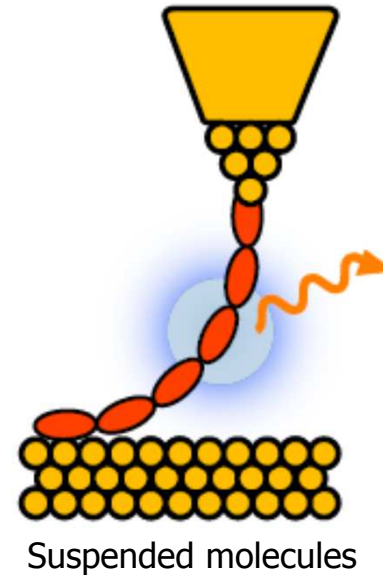

Single-molecule fluorescence with STM

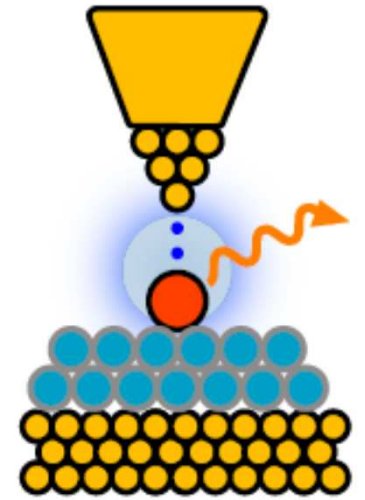

Molecules on insulating layer

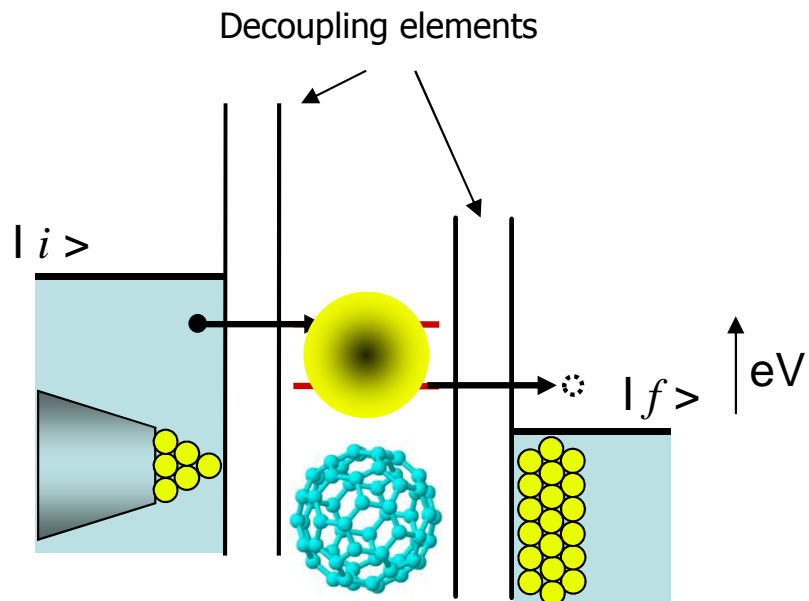

Single-molecule fluorescence with STM:

Molecules on insulating layer

Double tunneling junction

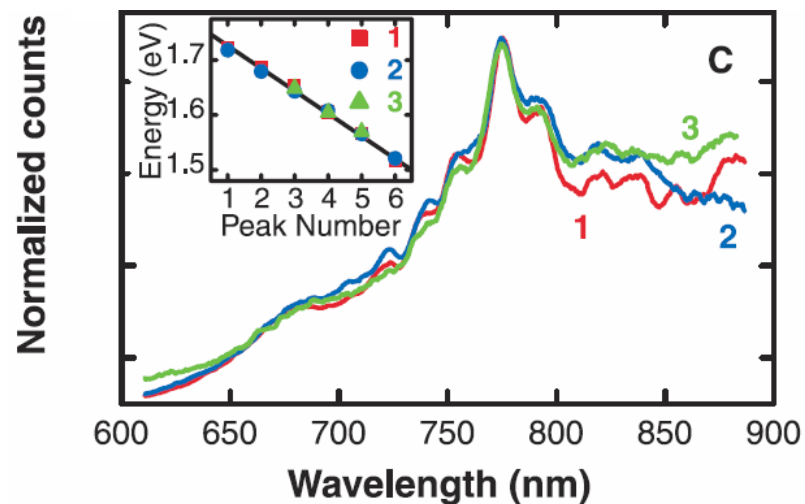
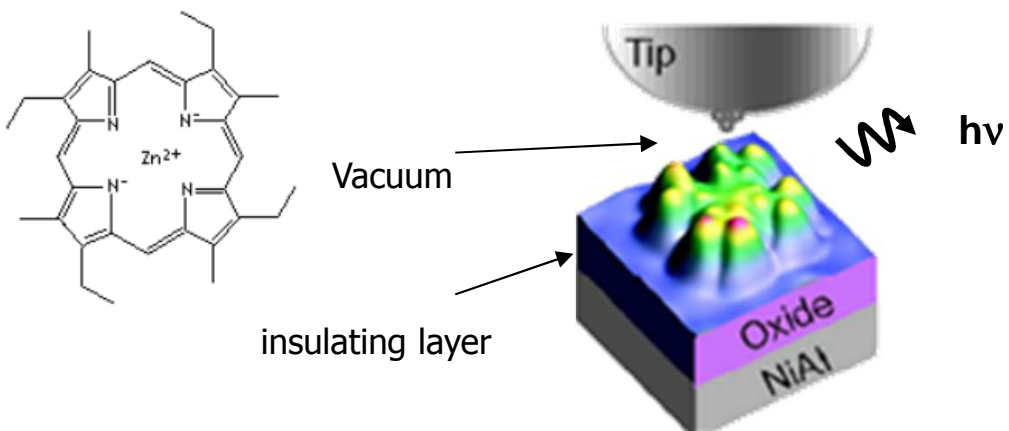

X. H. Qiu, G. V. Nazin, W. Ho, *Science*, 299, 542 (2003)

Intrinsic radiative transition

Lumo+1 -> Lumo transition (?)

Vibronic features

→ Chemical information ?

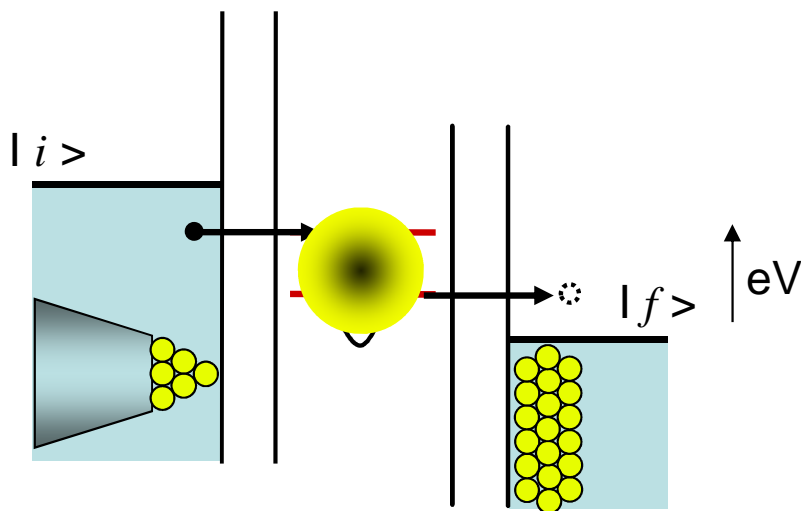

Preserves the imaging capability of the STM

Single-molecule fluorescence with STM: Molecules on insulating layer

Fluorescence microscopy with atomic-scale resolution ?

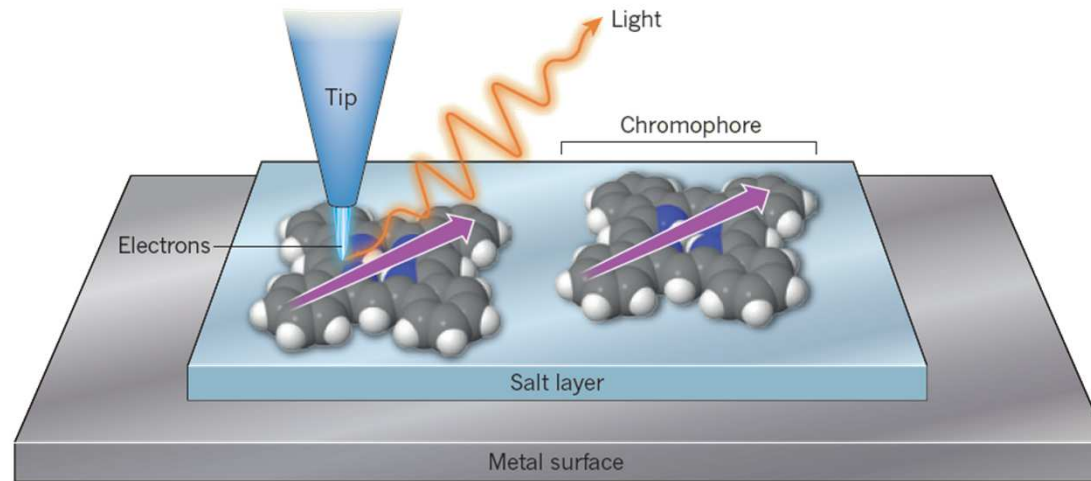

Zhenchao Dong's Group - Hefei National Laboratory, China

Y. Zhang *et al.*, Nature 531, 623 (2016)

Y. Zhang *et al.*, Nature Com. 8, 15225 (2017)

L. Zhang *et al.*, Nature Comm. 8, 580 (2017)

Youso kim's Group - Riken Laboratory, Japan

H. Imada *et al.*, Nature 538, 364 (2016)

H. Imada *et al.*, Phys. Rev. Lett. 119 013901 (2017)

K. Miwa *et al.*, Nano Lett. asap (2019)

IPCMS

B. Doppagne *et al.*, Phys. Rev. Lett. 118, 127401 (2017)

J. Kroeger *et al.*, Nanoletters 18, 3407 (2018)

B. Doppagne *et al.* Science, 361, 251 (2018)

fluorescence of single-molecule

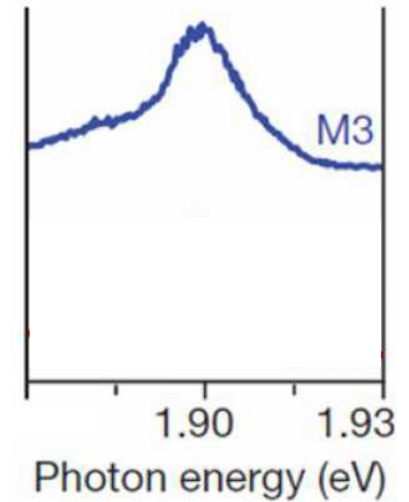
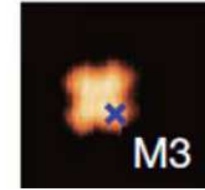
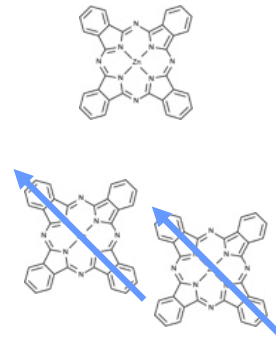
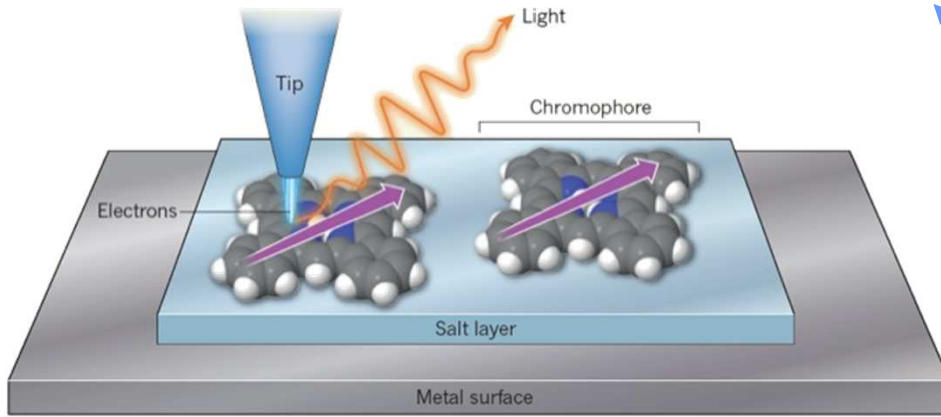

Coherent coupling between molecular dipoles

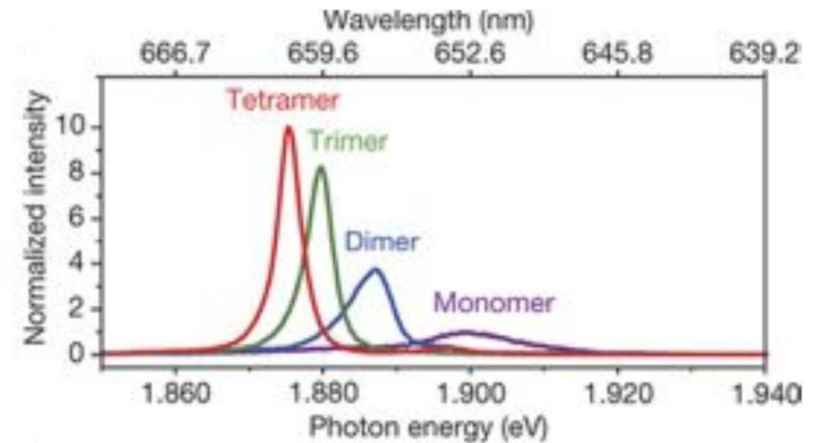
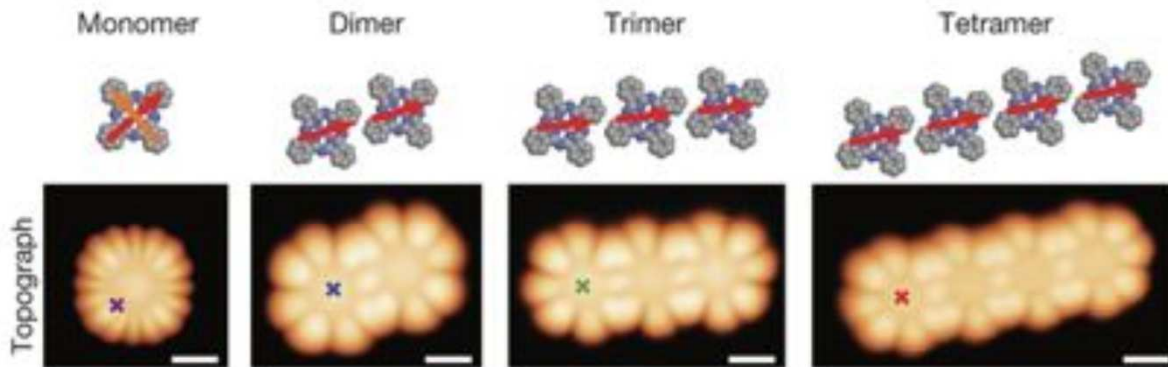

Building a J-aggregate molecule per molecule

Single-molecule fluorescence with STM: Molecules on insulating layer

Y. Zhang *et al.*
Nature 531, 623 (2016).

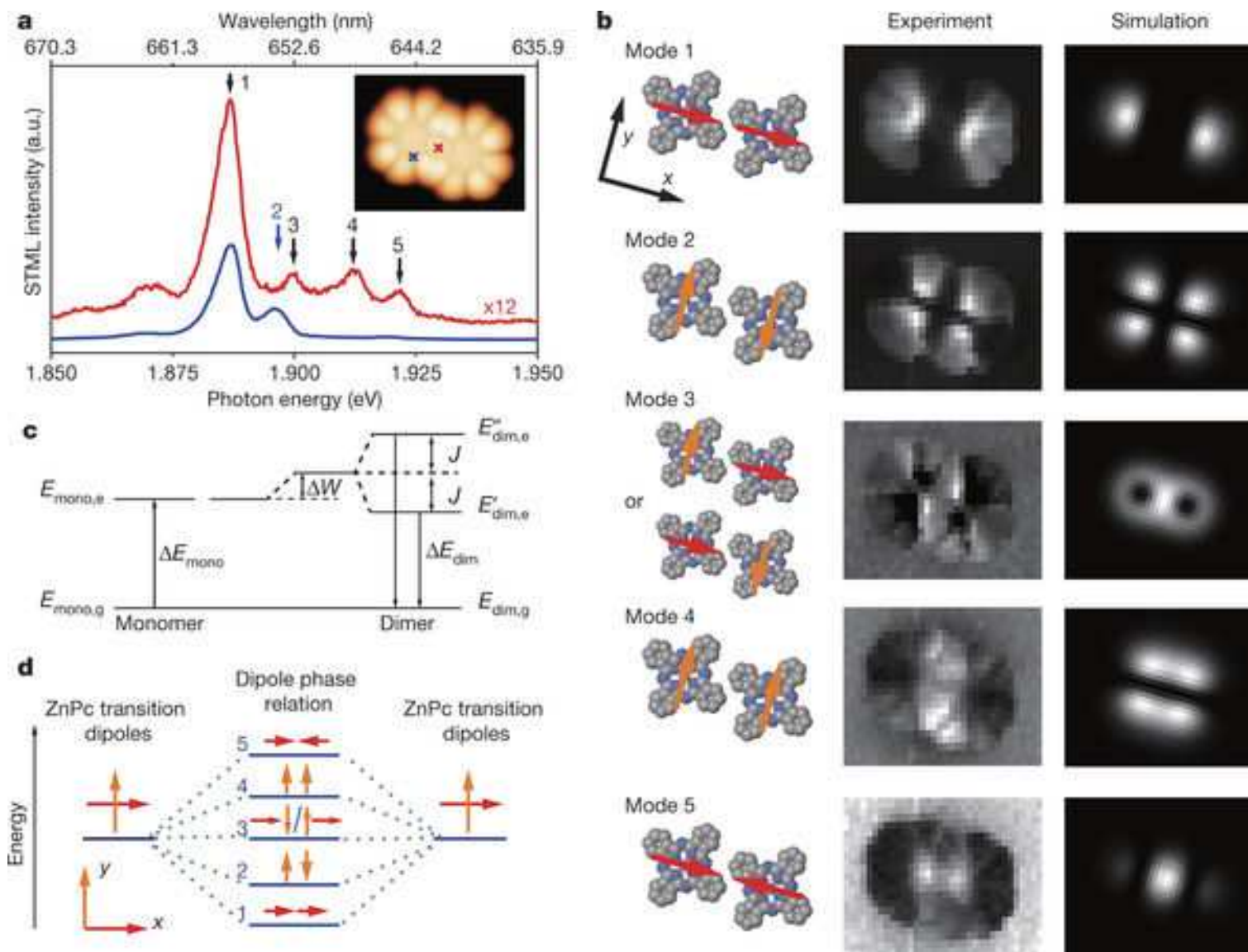

Fluorescence imaging with sub-molecular resolution

Single-molecule fluorescence with STM: Molecules on insulating layer

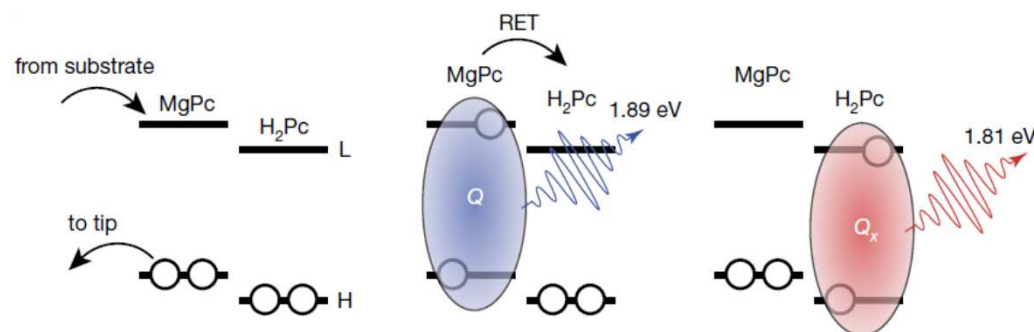
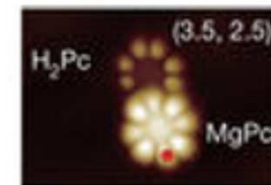
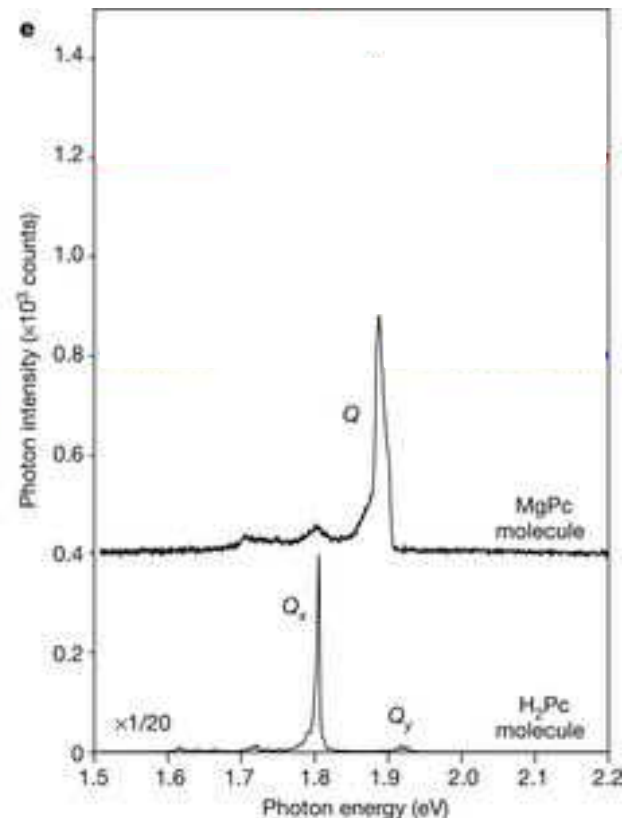
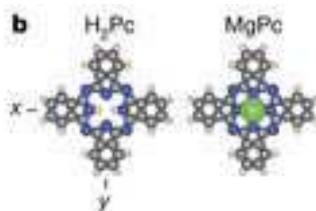
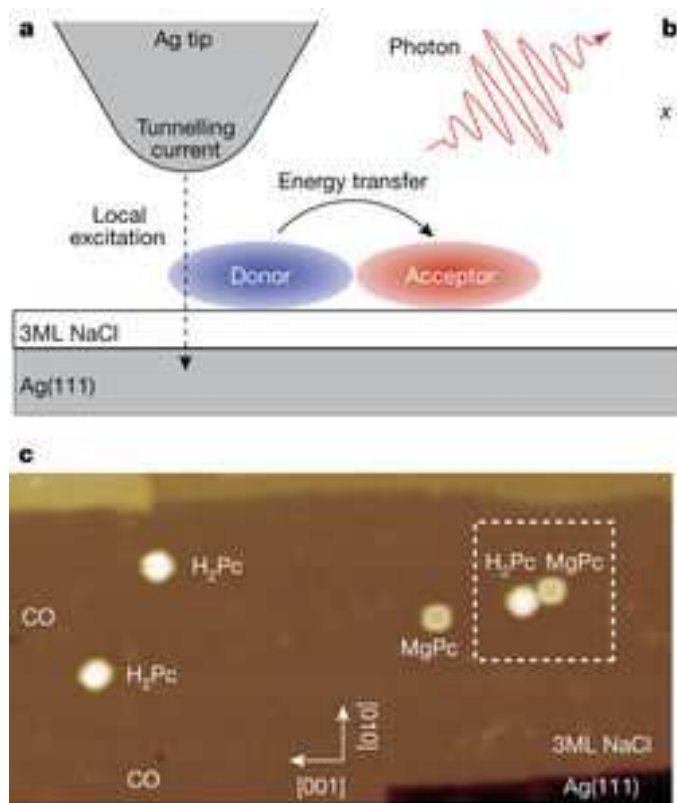

H. Imada *et al.*,
Nature 538, 364 (2016)

Energy transfer between two molecules

fluorescence of single-molecule

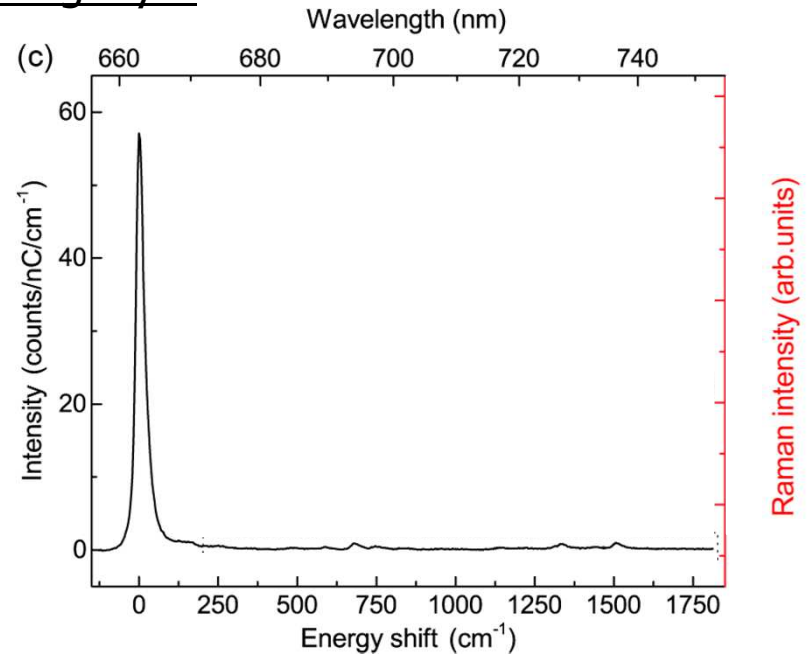
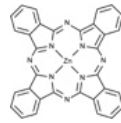
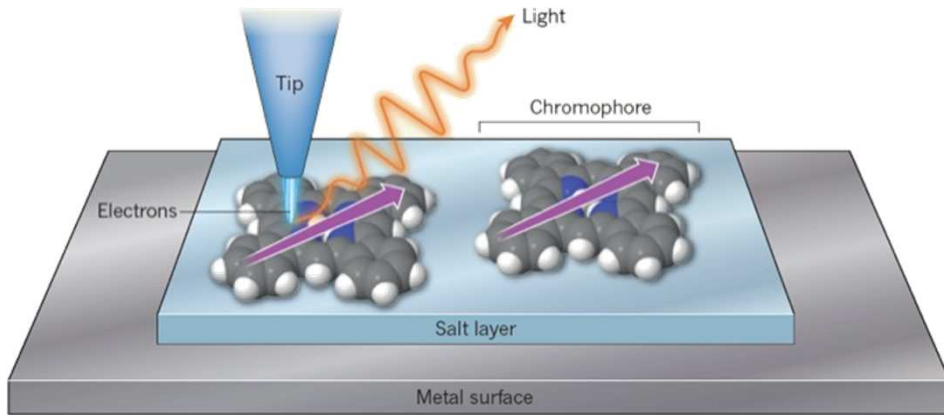

Raman spectroscopy

Etienne Lorchat - Stéphane Berciaud
IPCMS

STM image

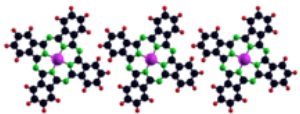
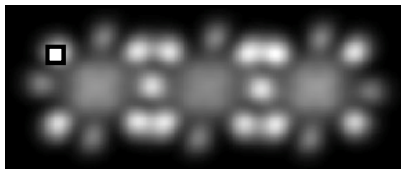

- Same informations as that obtained in Raman spectroscopy on a **single-molecule**.
- **Vibronic fingerprint of the molecule**

Single-molecule fluorescence with STM: Molecules on insulating layer

fluorescence of single-molecule

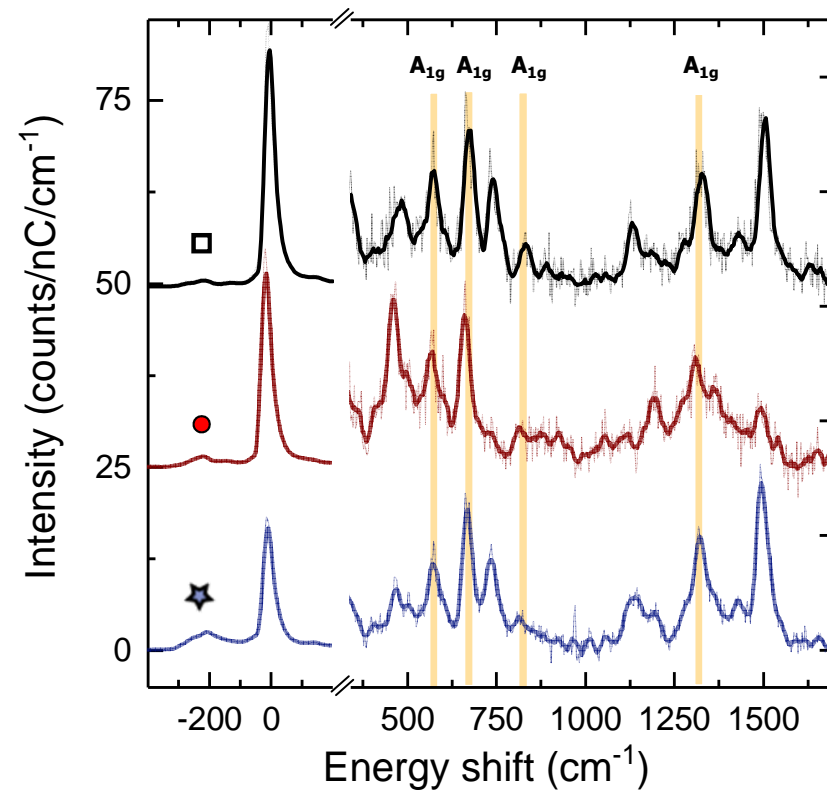
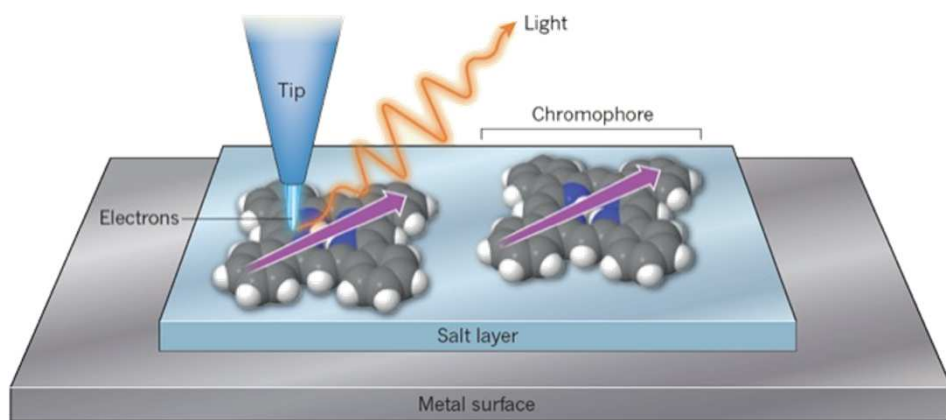

STM image

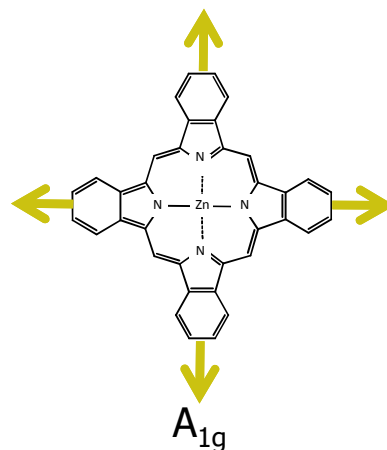
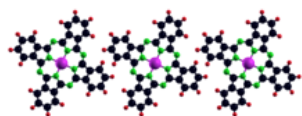

fluorescence of single-molecule

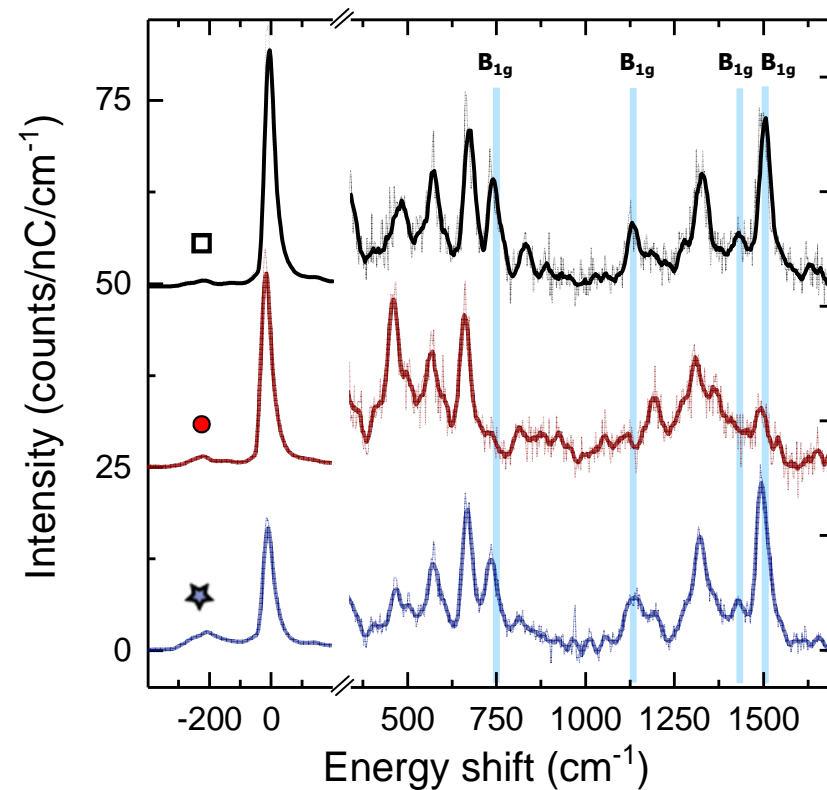
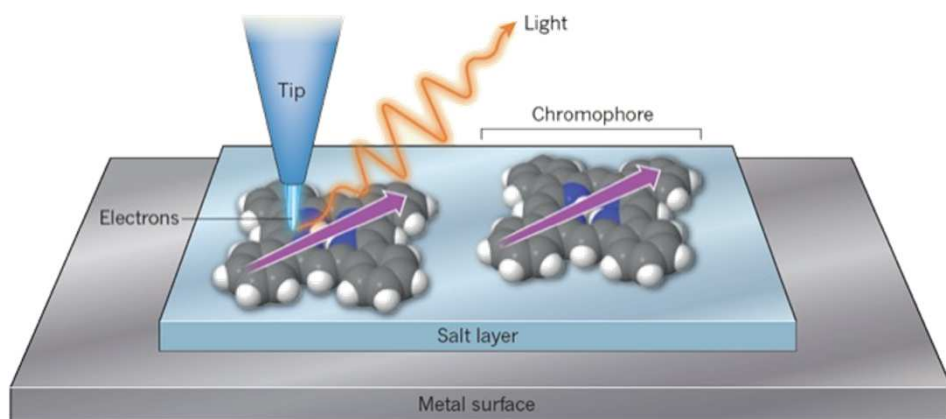

STM image

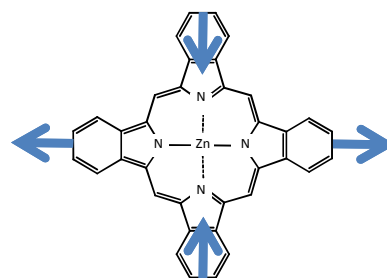
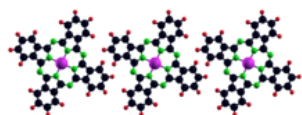

B_{1g}

fluorescence of single-molecule

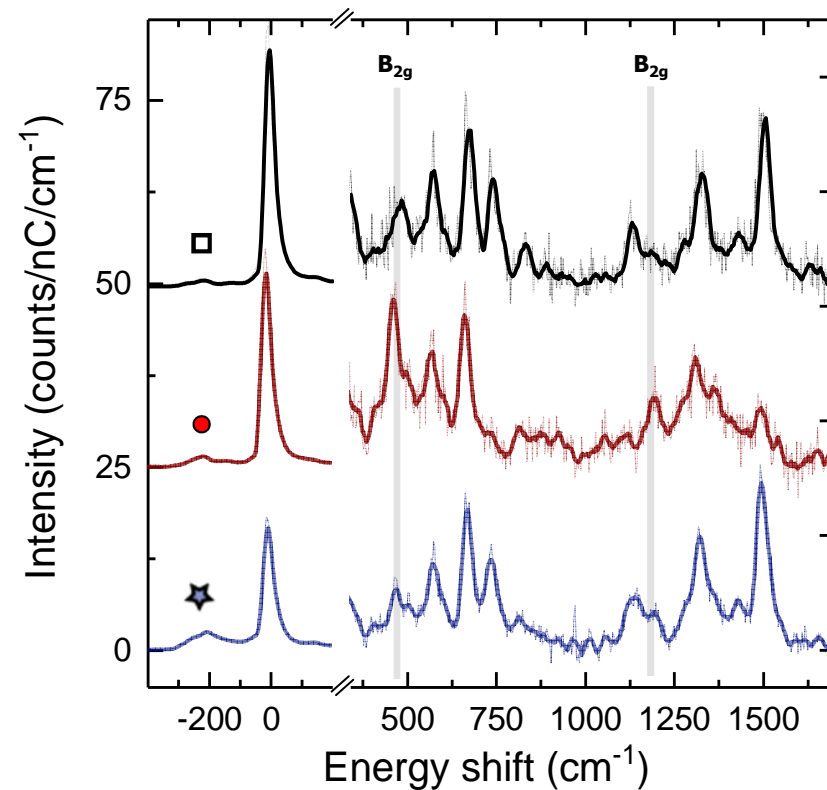
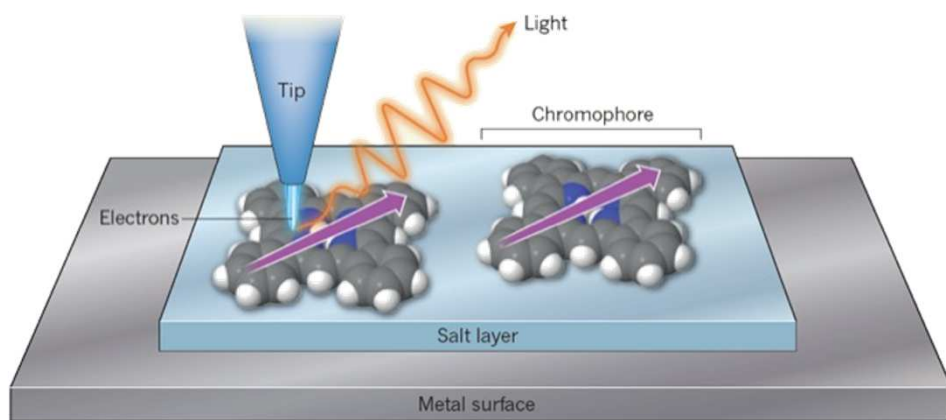

STM image

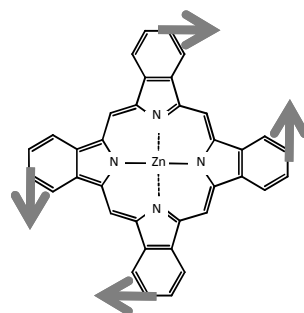
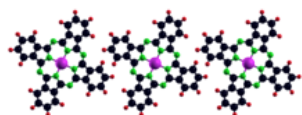

B_{2g}

Peaks associated to modes having the same symmetry have similar spatial distribution ?

Single-molecule fluorescence with STM:

Molecules on insulating layer

fluorescence of single-molecule

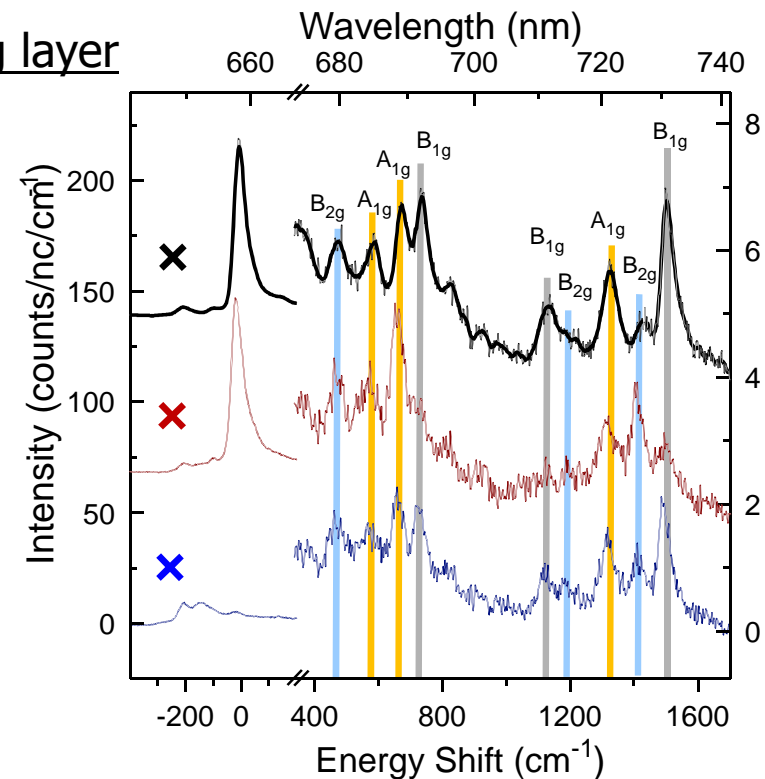
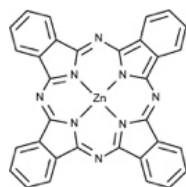
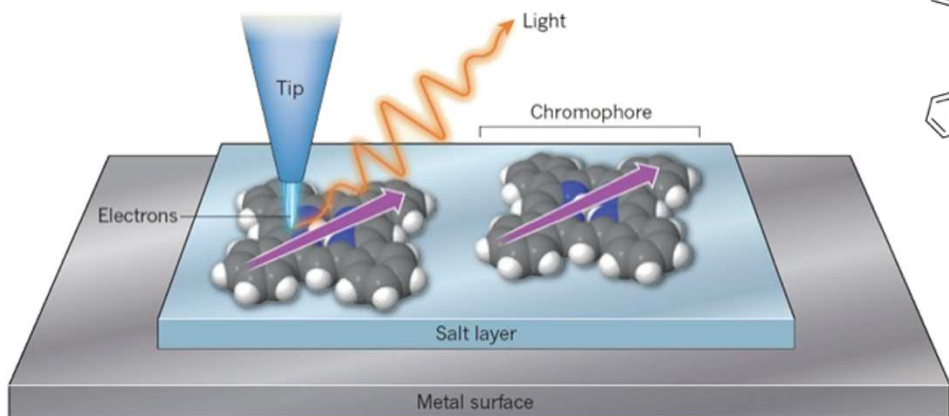

Poster: Benjamin Doppagne

STM image

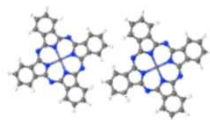
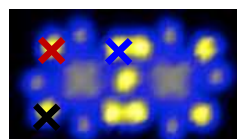

Energy resolved photon maps (acq. time 19H)

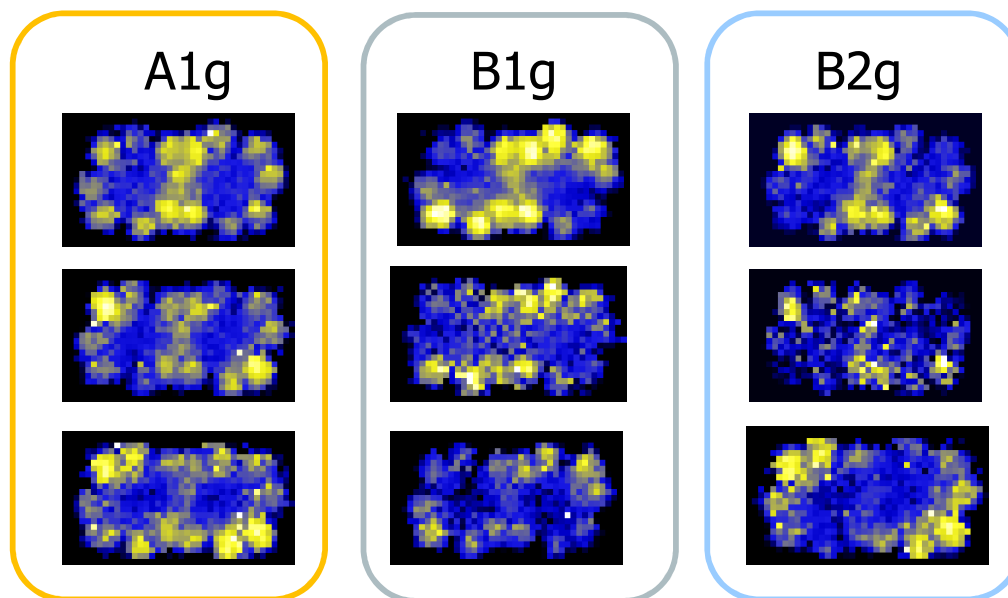

Vibratic spectroscopy with
submolecular resolution

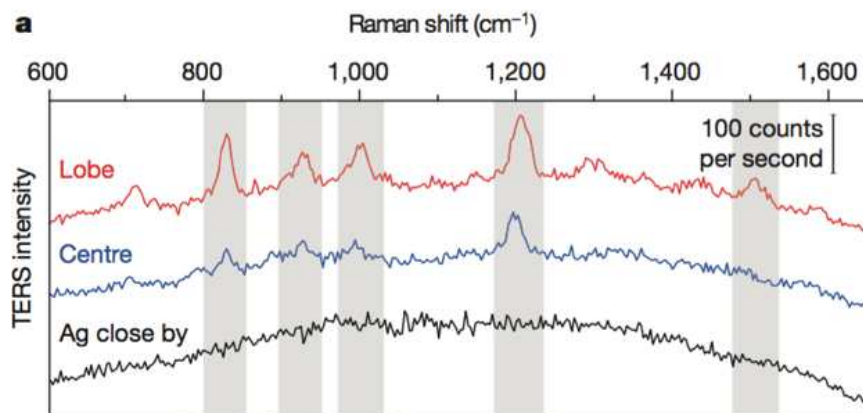
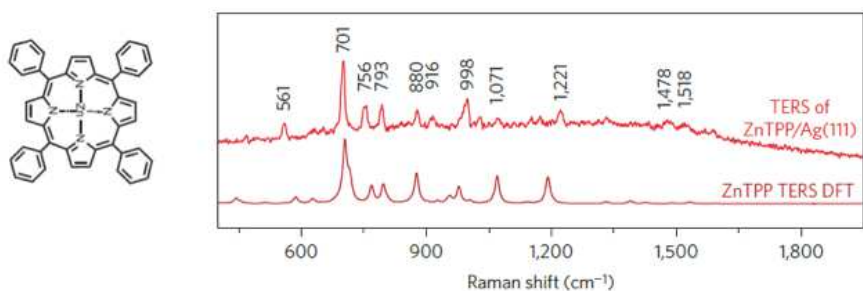
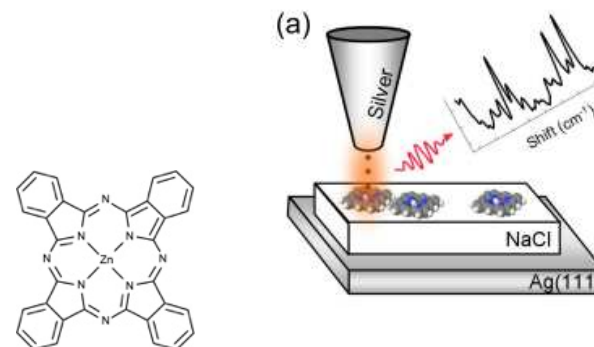
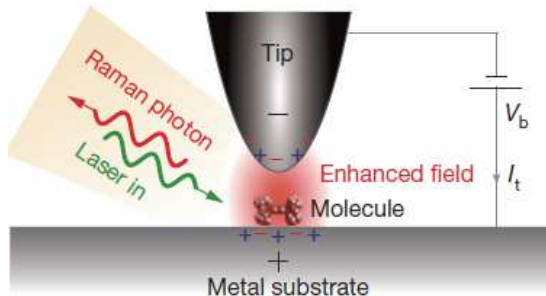

R. Zhang *et al.* **Chemical mapping of a single molecule by plasmon-enhanced Raman scattering**
Nature 498, 82 (2013)

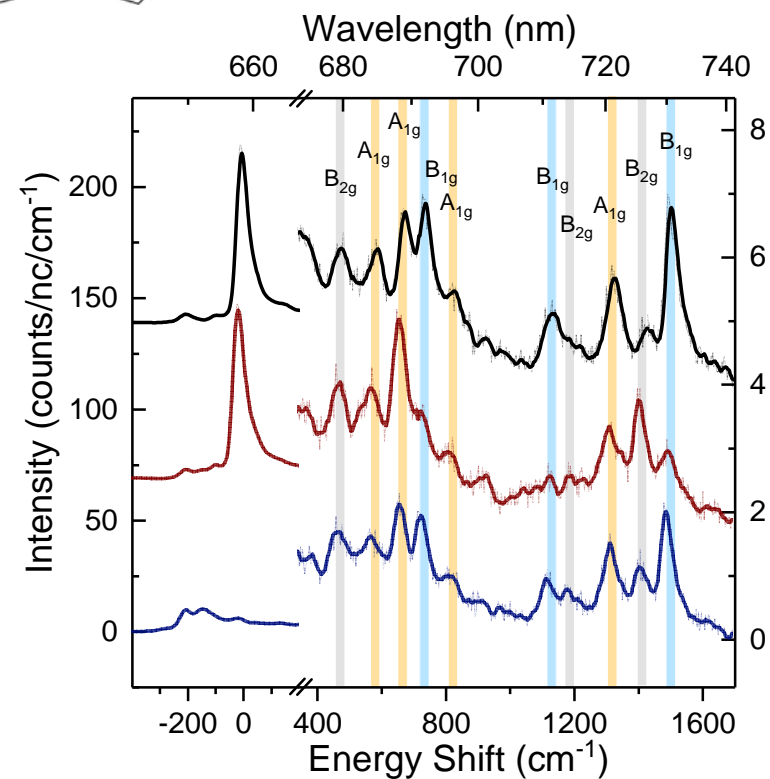

A1g

B1g

B2g

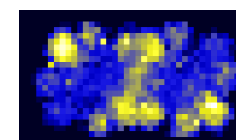
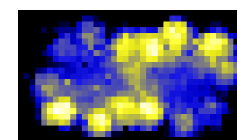
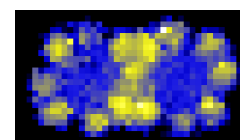

B. Doppagne *et al.* *Phys. Rev. Lett.* 118, 127401 (2017)

Combining spatial- and time-resolved fluorescence microscopy

Courtesy of Fabrice Charra
CEA Saclay

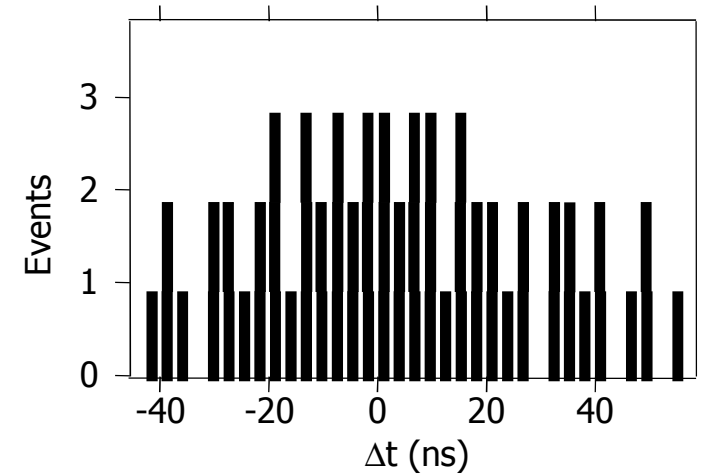
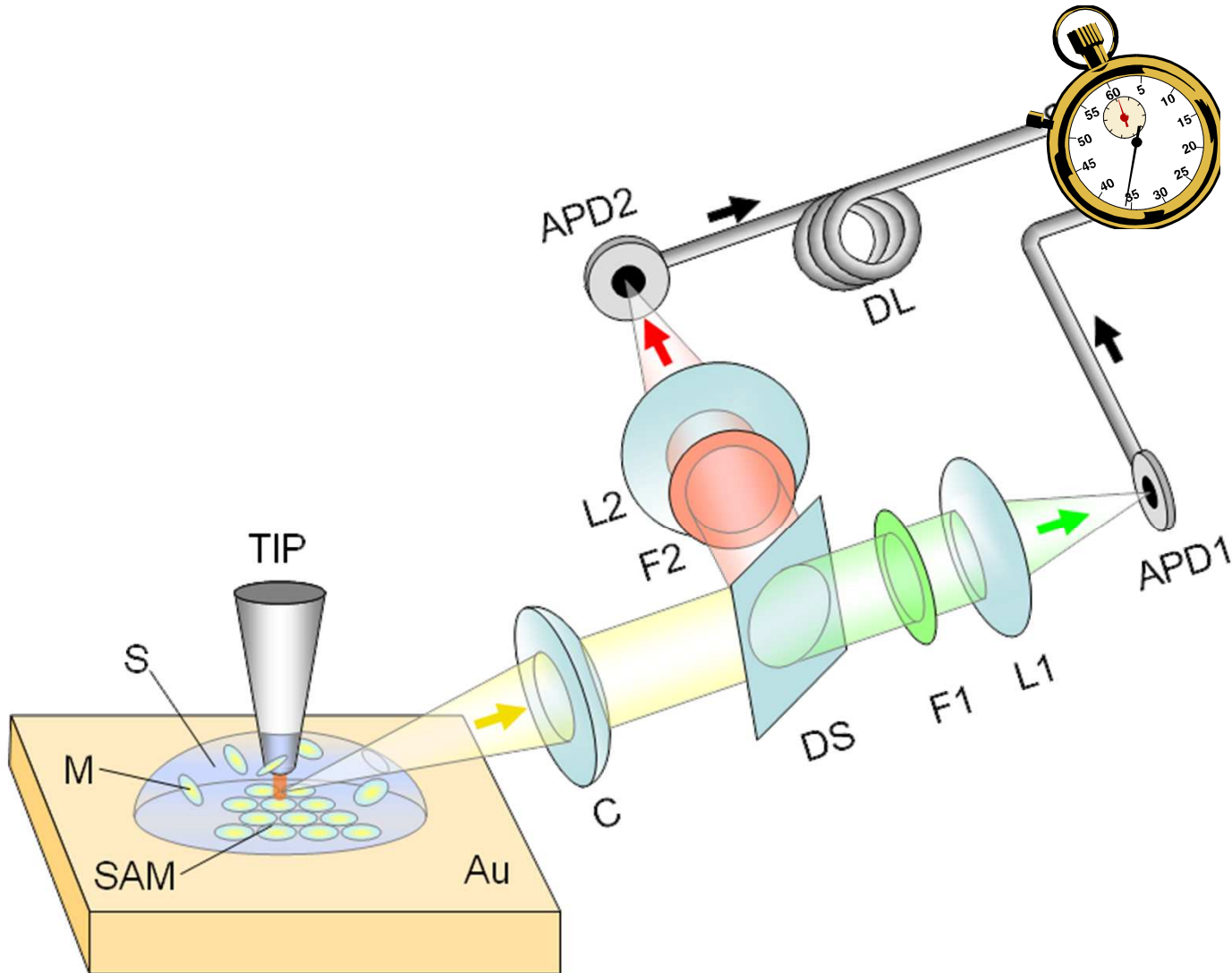

Probabilité de détecter
un photon au temps Δt
si un photon est
détecté au temps 0

Combining spatial- and time-resolved fluorescence microscopy

fluorophore

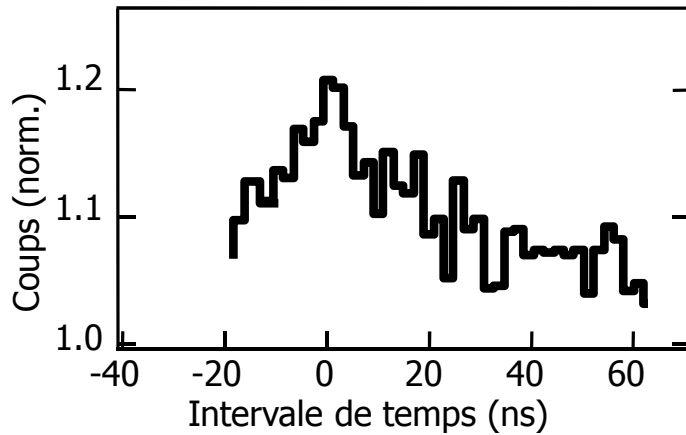
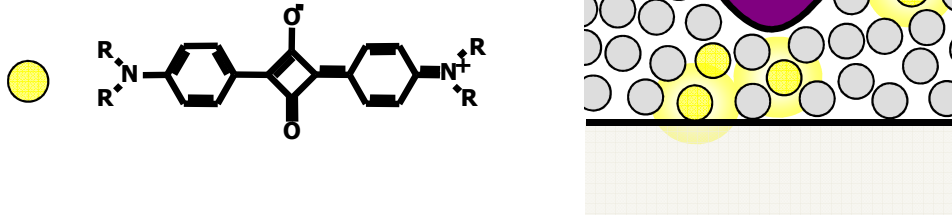

F. Silly *et al.* *Appl. Phys. Lett.* 77, 3648 (2000).

K. Perronet *et al.*, *Europhys Lett.* 74, 313 (2006).

**Measuring fluctuations
with nanosecond
accuracy**

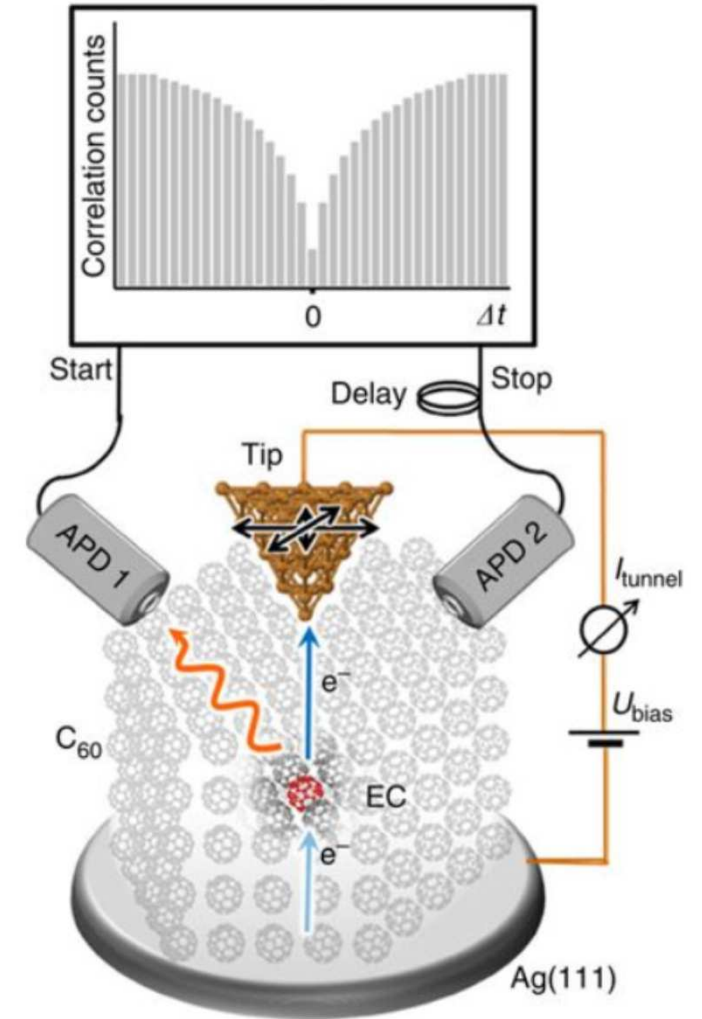

P. Merino *et al.* *Nature Comm.* 6, 8461 (2015).

**Single photon sources
from defects in C60
multilayers**

Combining spatial- and time-resolved fluorescence microscopy

Single - photon sources from single molecule excited by STM

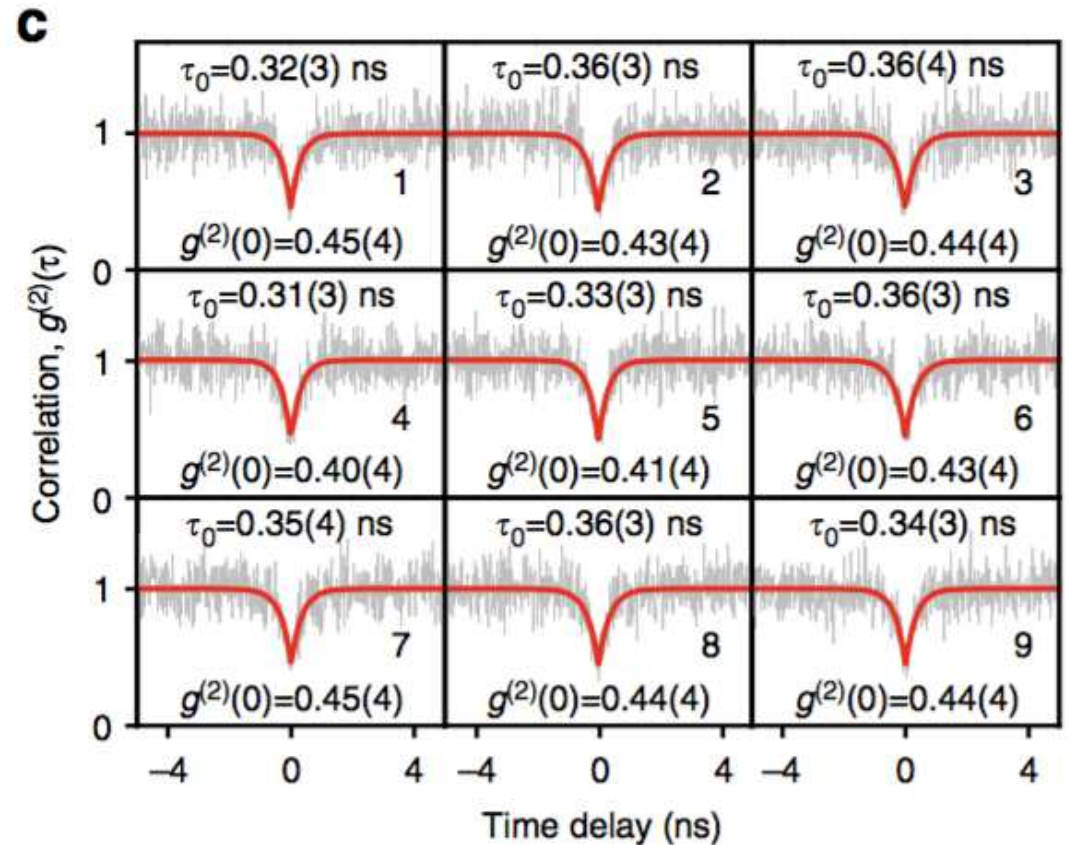
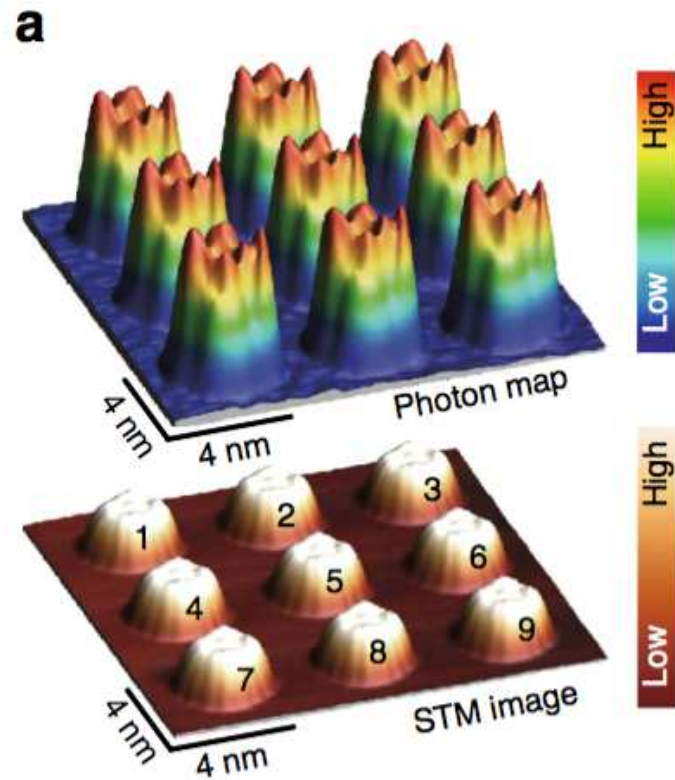

Time resolution

Spatial resolution

Spectral resolution

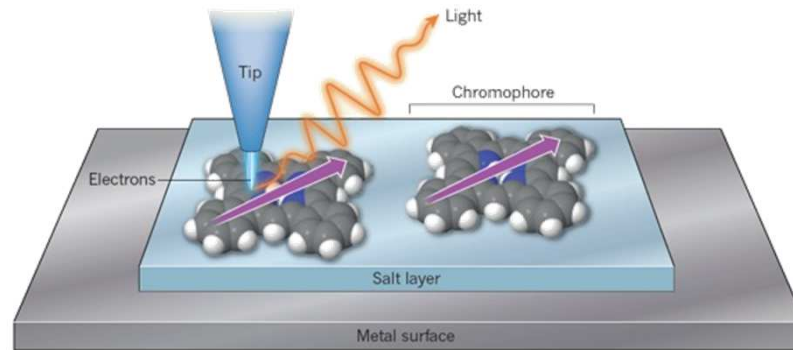

Combining spatial and time-resolved fluorescence microscopy

Can we also control the **redox state** of the probed molecule ?

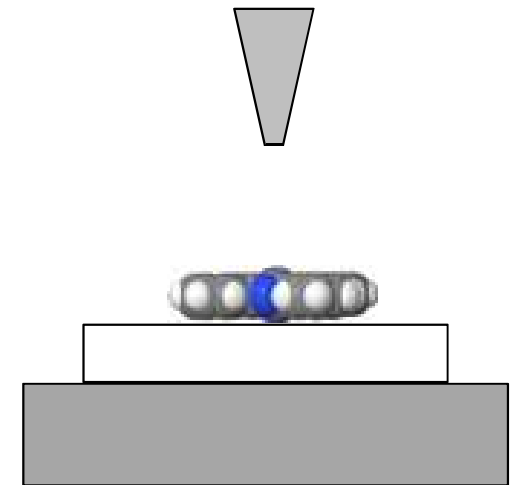

Time resolution

Spatial resolution

Spectral resolution

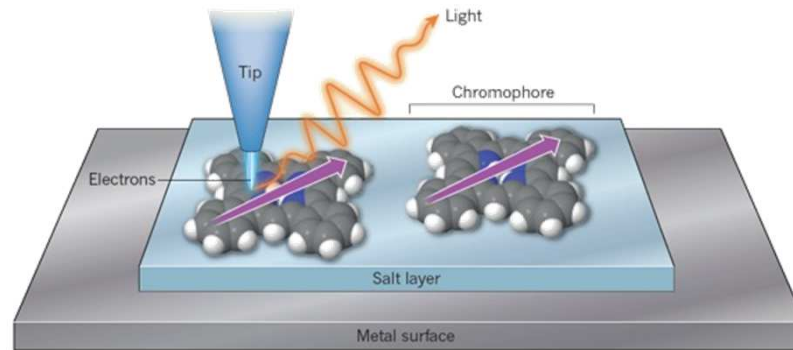

Combining spatial and time-resolved fluorescence microscopy

Can we also control the **redox state** of the probed molecule ?

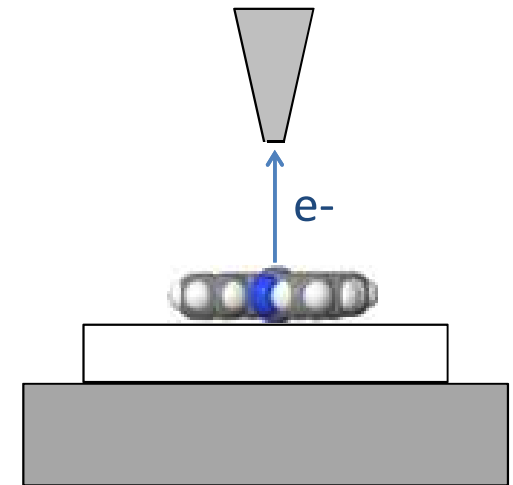

Time resolution

Spatial resolution

Spectral resolution

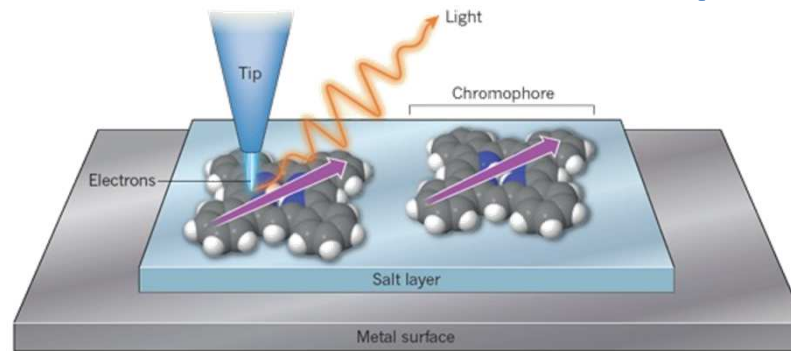

Combining spatial and time-resolved fluorescence microscopy

Can we also control the **redox state** of the probed molecule ?

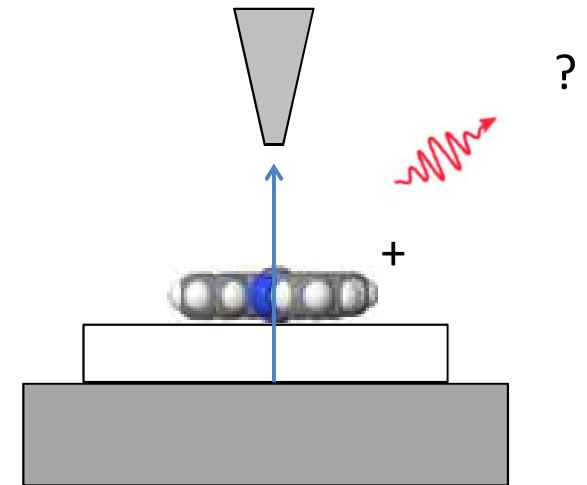

Fluorescence of a charged molecule ?

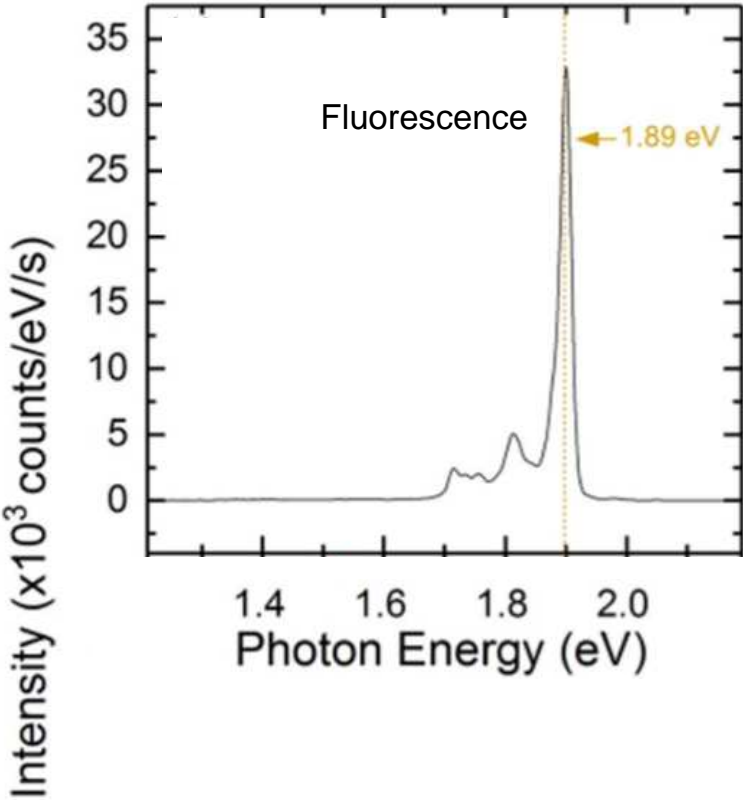
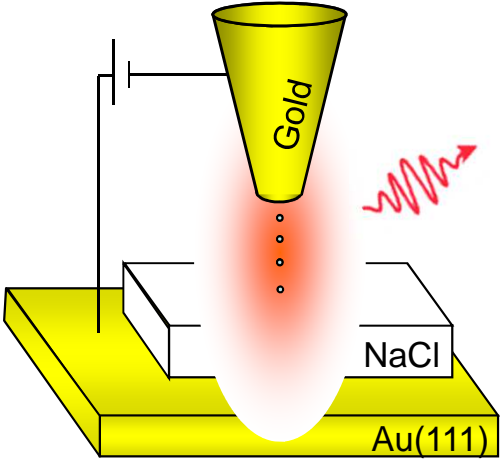
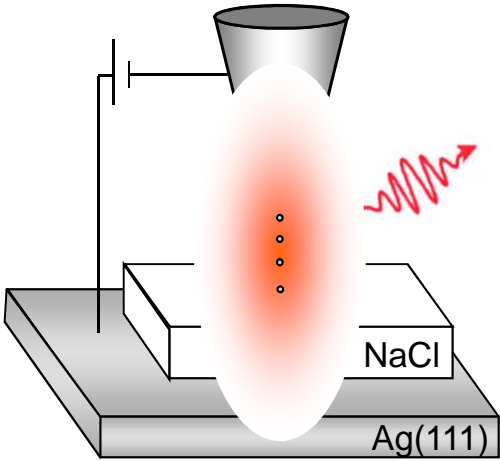

Fluorescence of a charged molecule ?

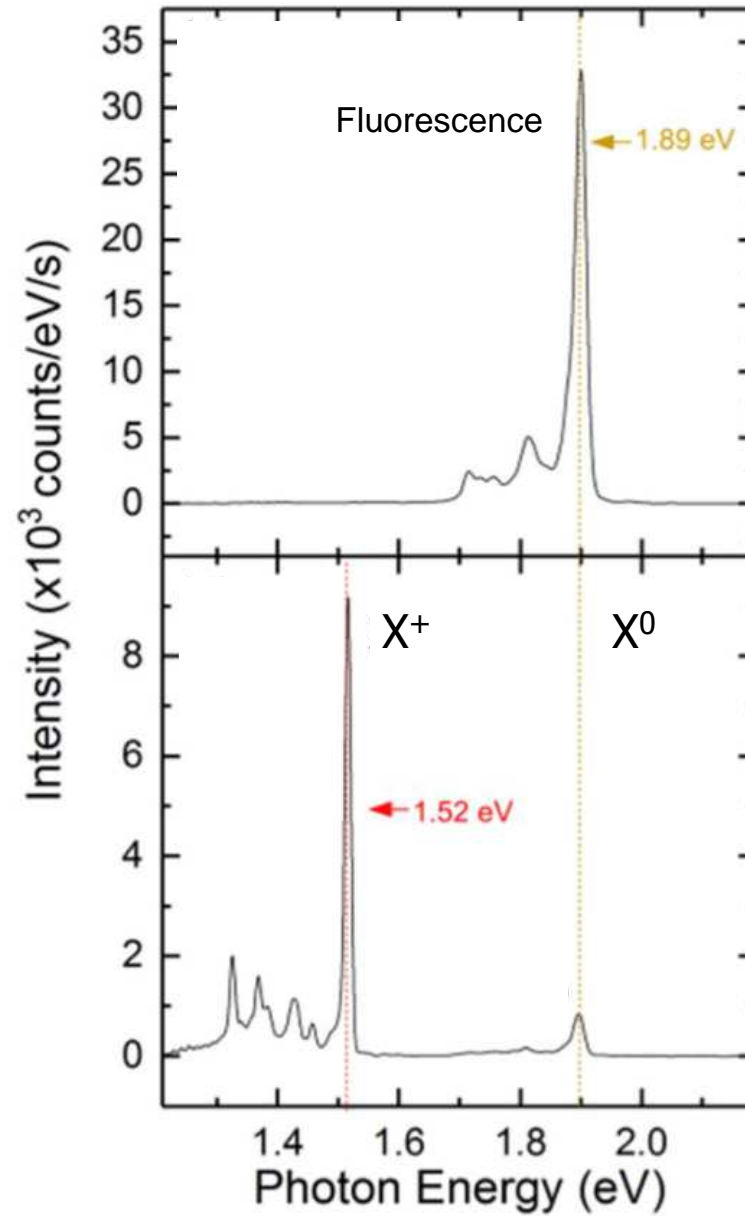
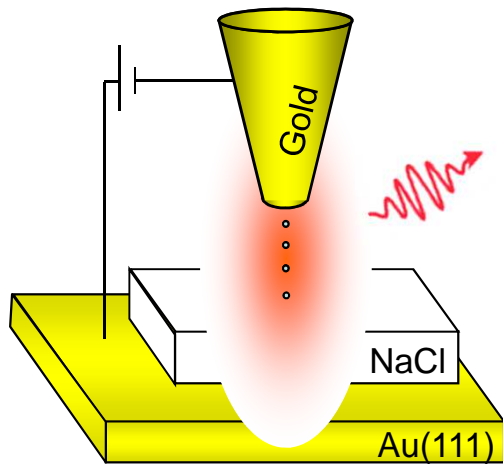
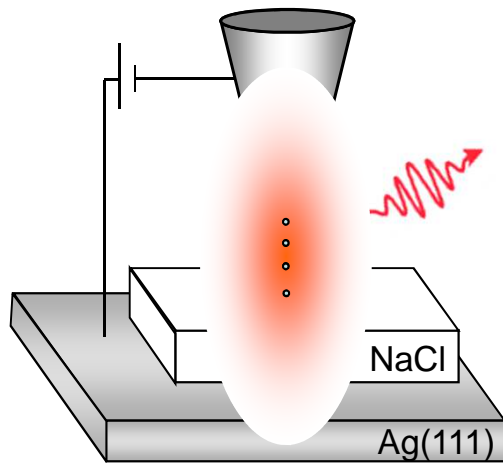

X^+ = radical cation of ZnPc

X^0 = ZnPc

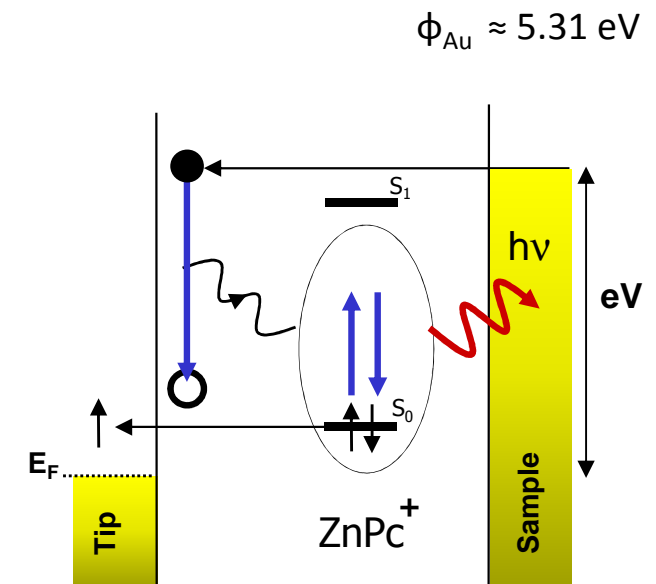

Fluorescence of a ZnPc radical cation

Fluorescence of a charged molecule ?

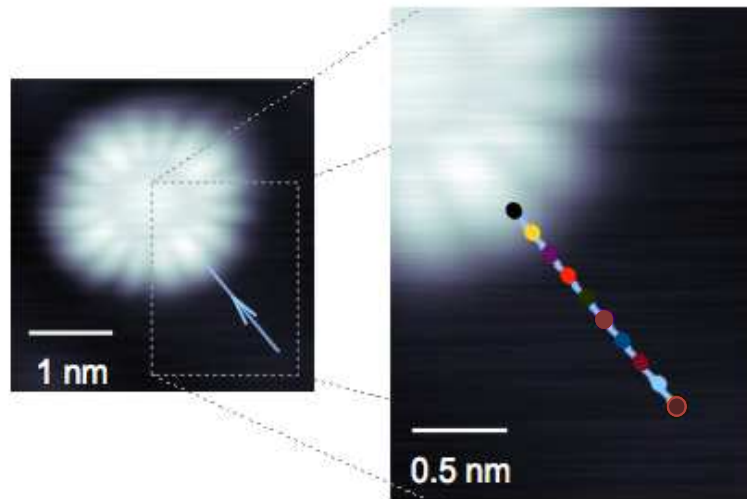
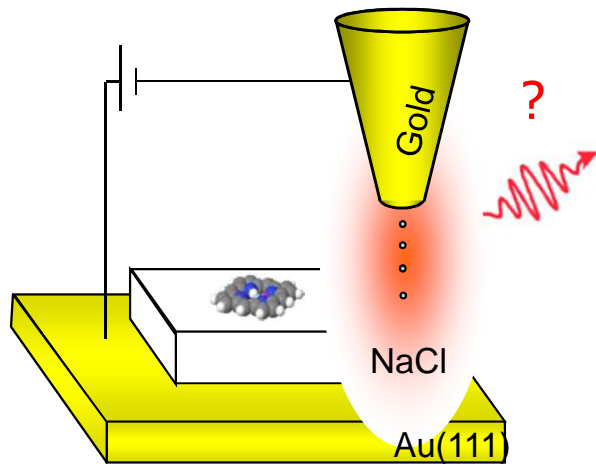

Fluorescence of a charged molecule ?

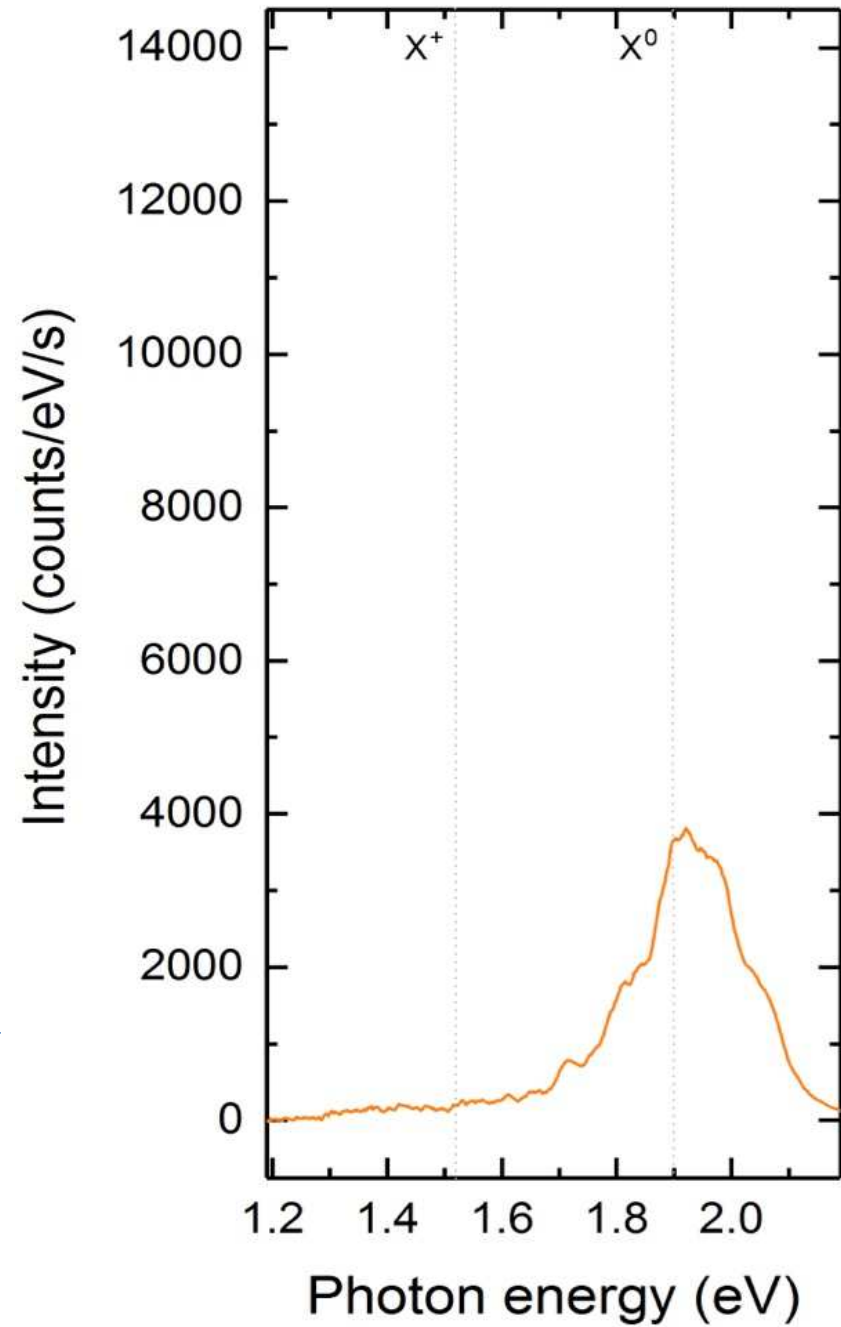
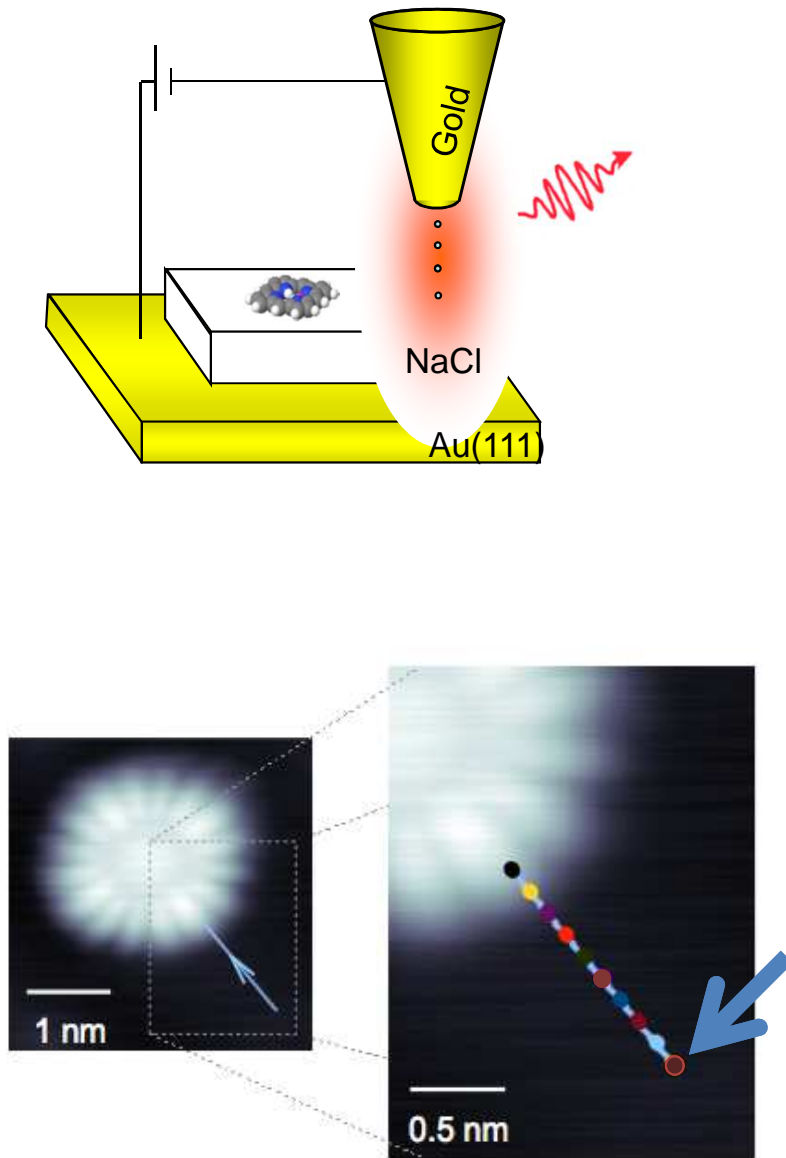

Fluorescence of a charged molecule ?

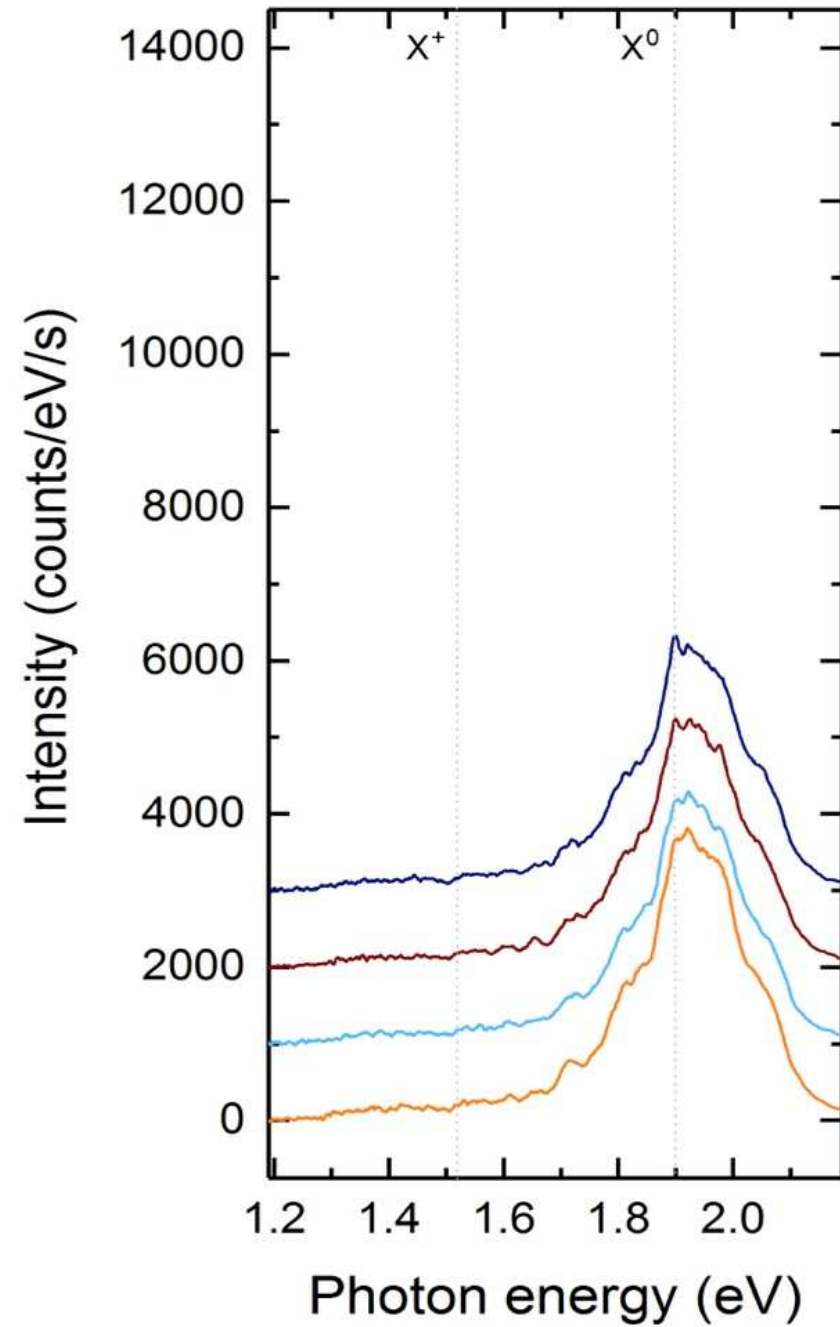
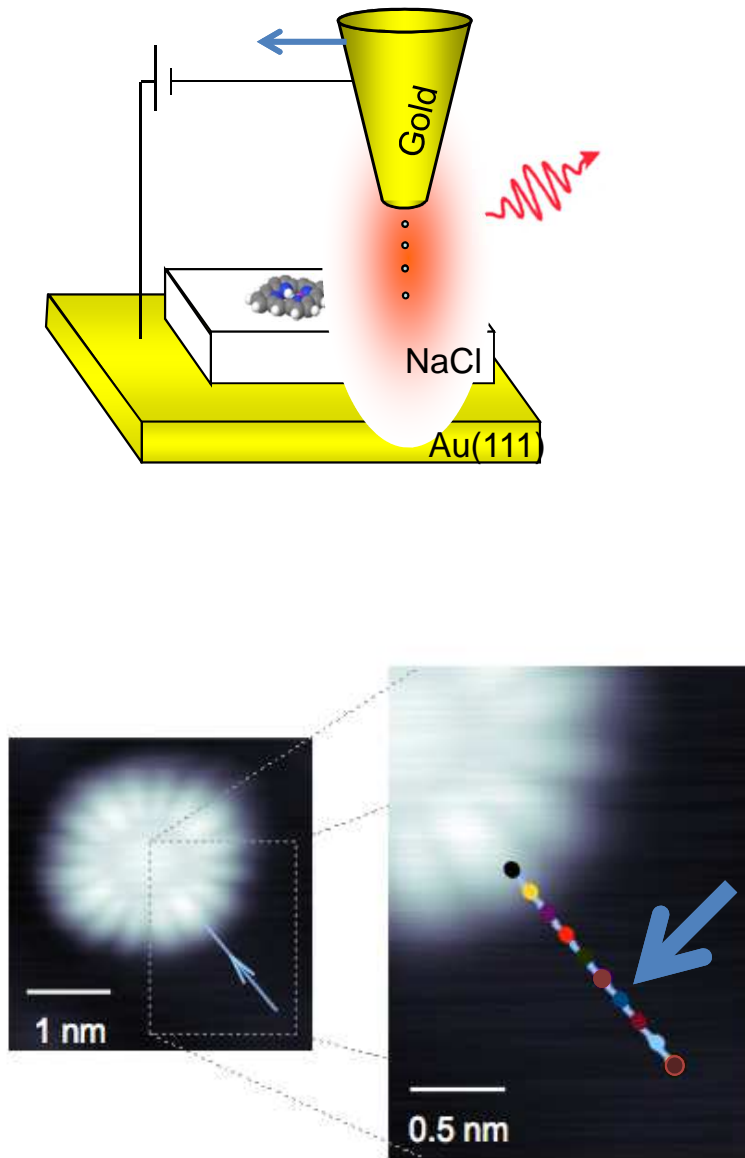

Fluorescence of a charged molecule ?

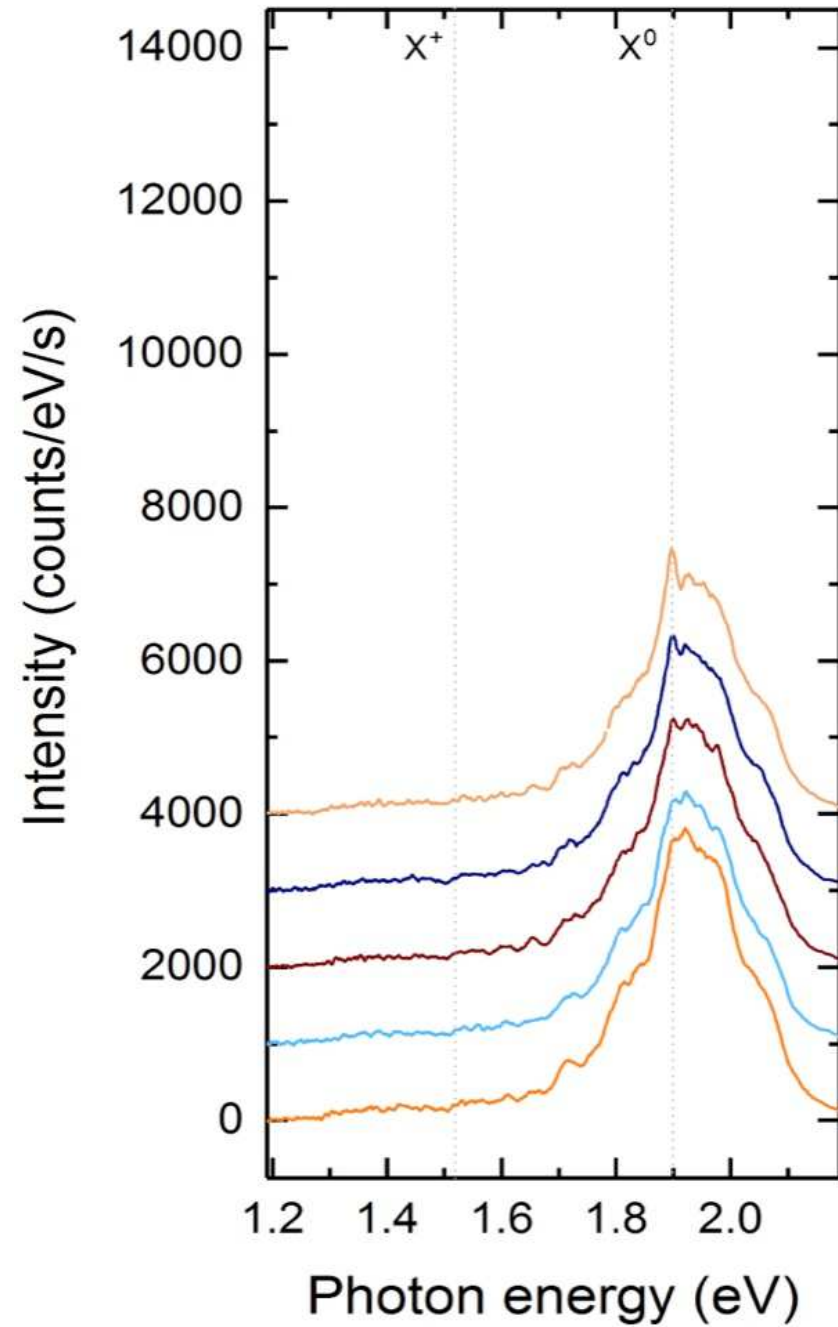
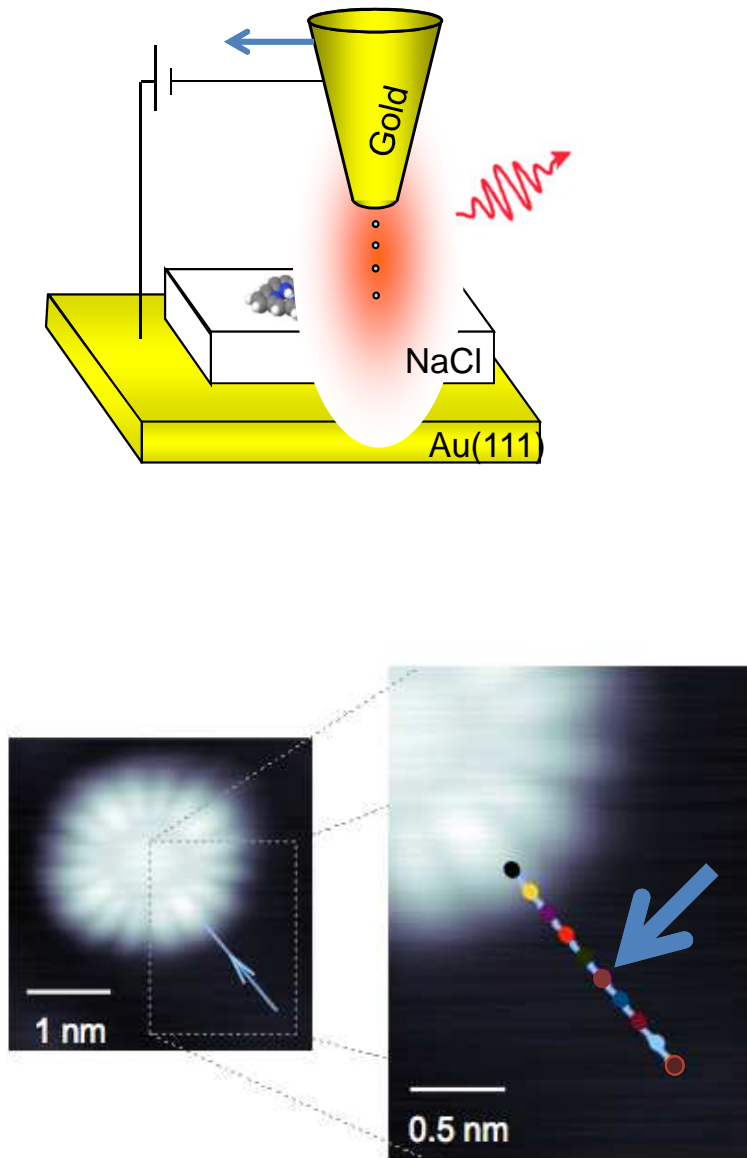

Fluorescence of a charged molecule ?

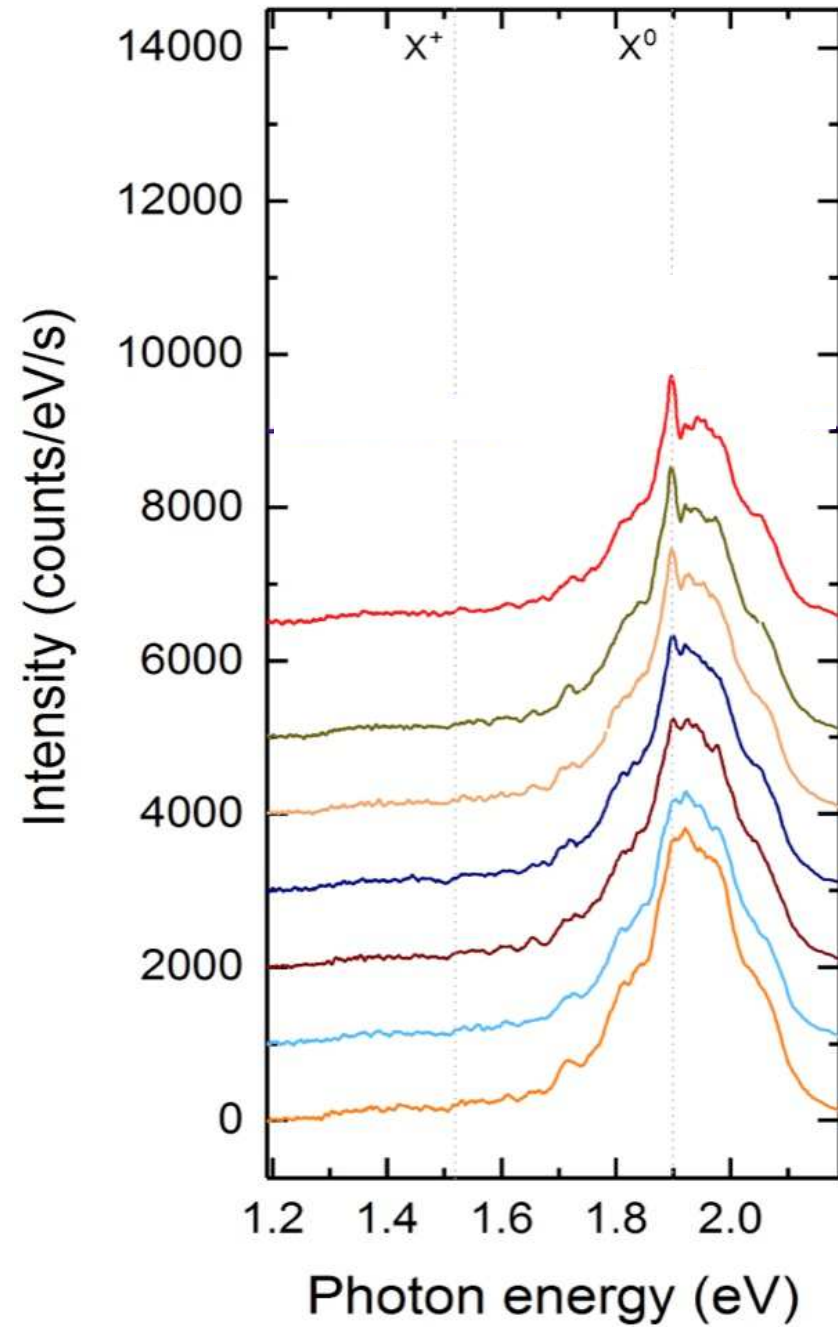
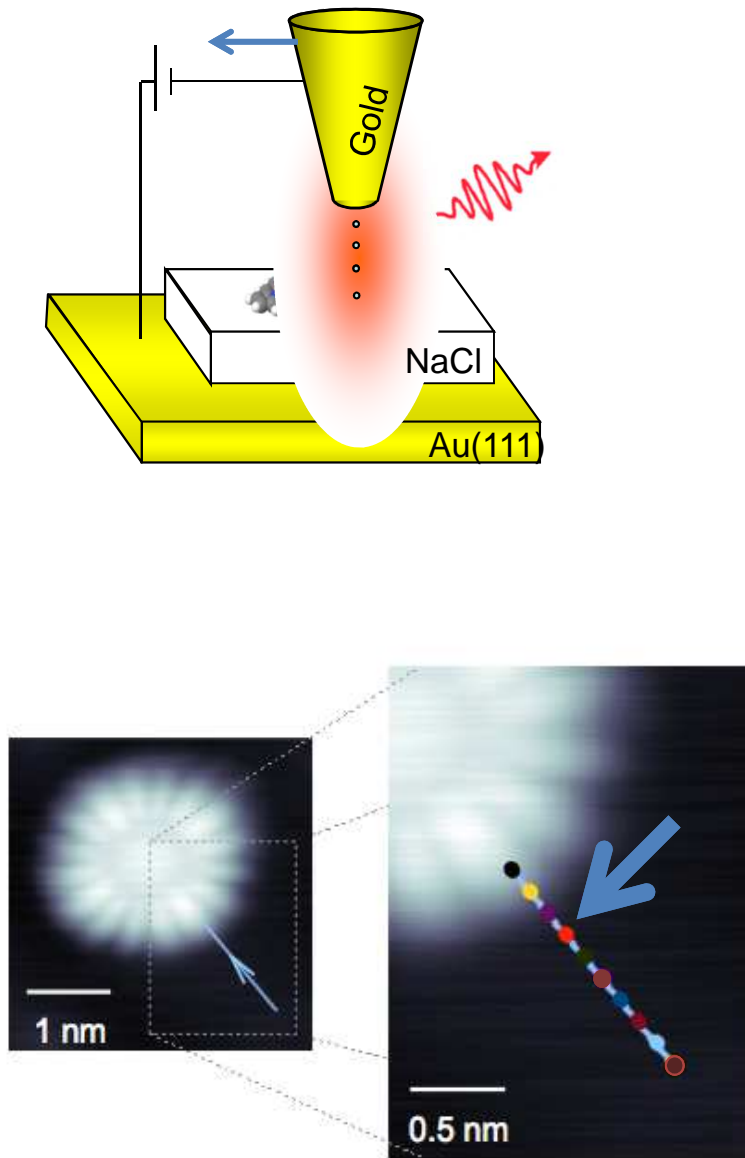

Control of the Exciton – Plasmon coupling at the atomic-scale

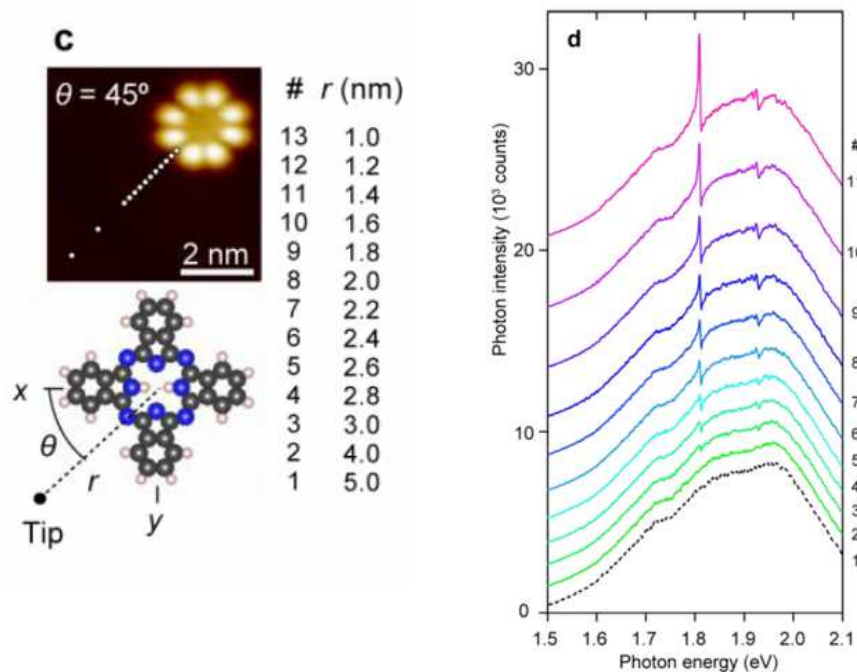

H. Imada *et al.* Phys. Rev. Lett. 119, 013901 (2017)

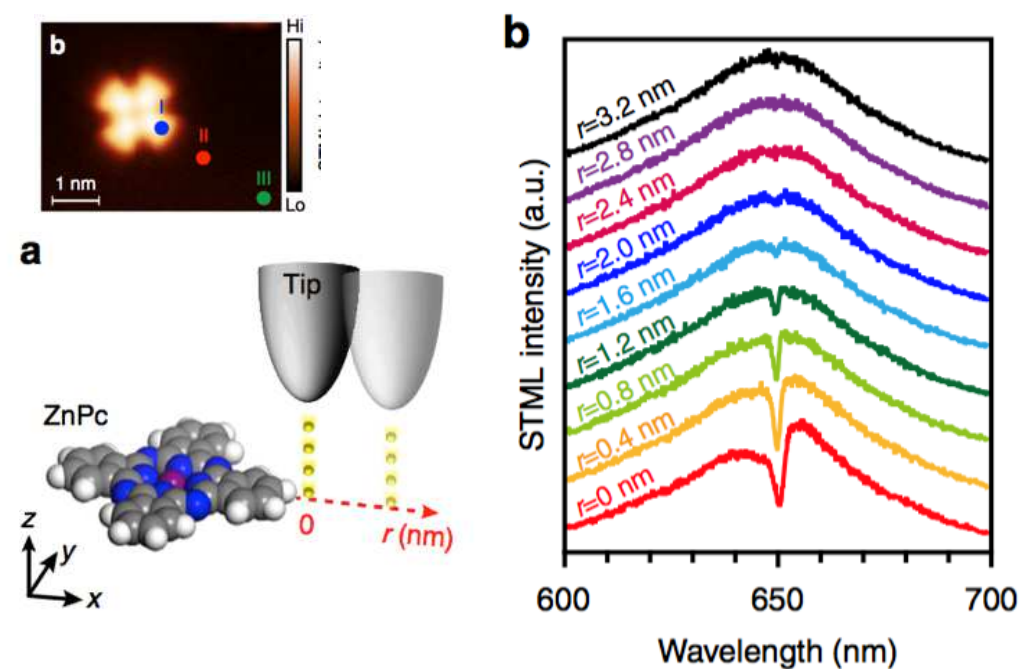

Y. Zhang *et al.* Nature Comm. 8, 15225 (2017)

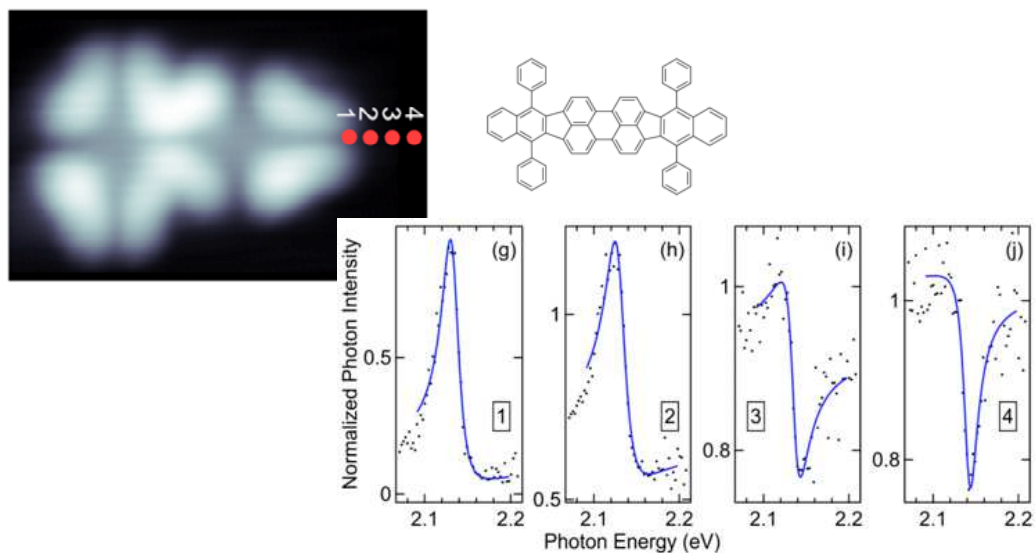

J. Kroeger *et al.* Nanoletters 18, 3407 (2018)

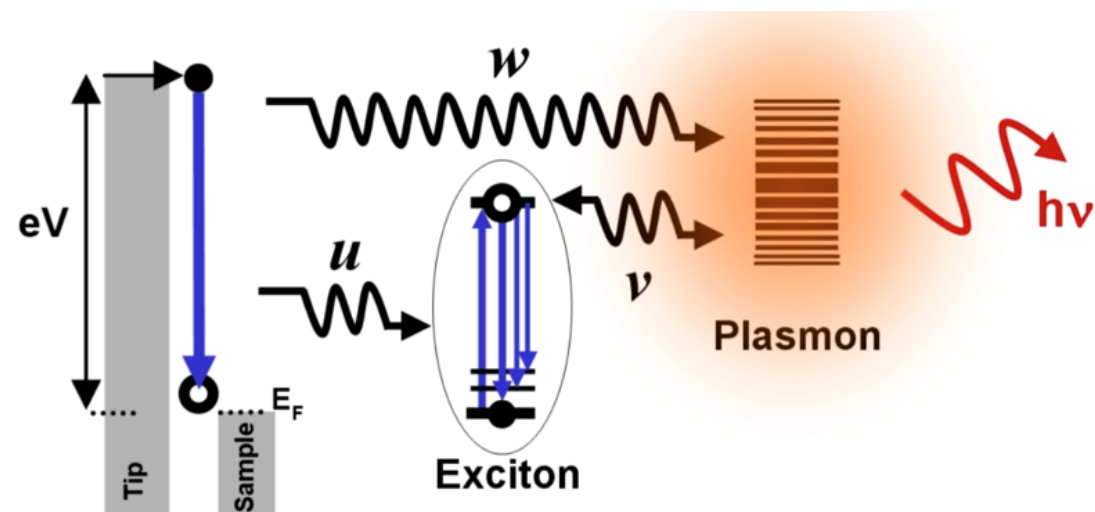

Fluorescence of a charged molecule ?

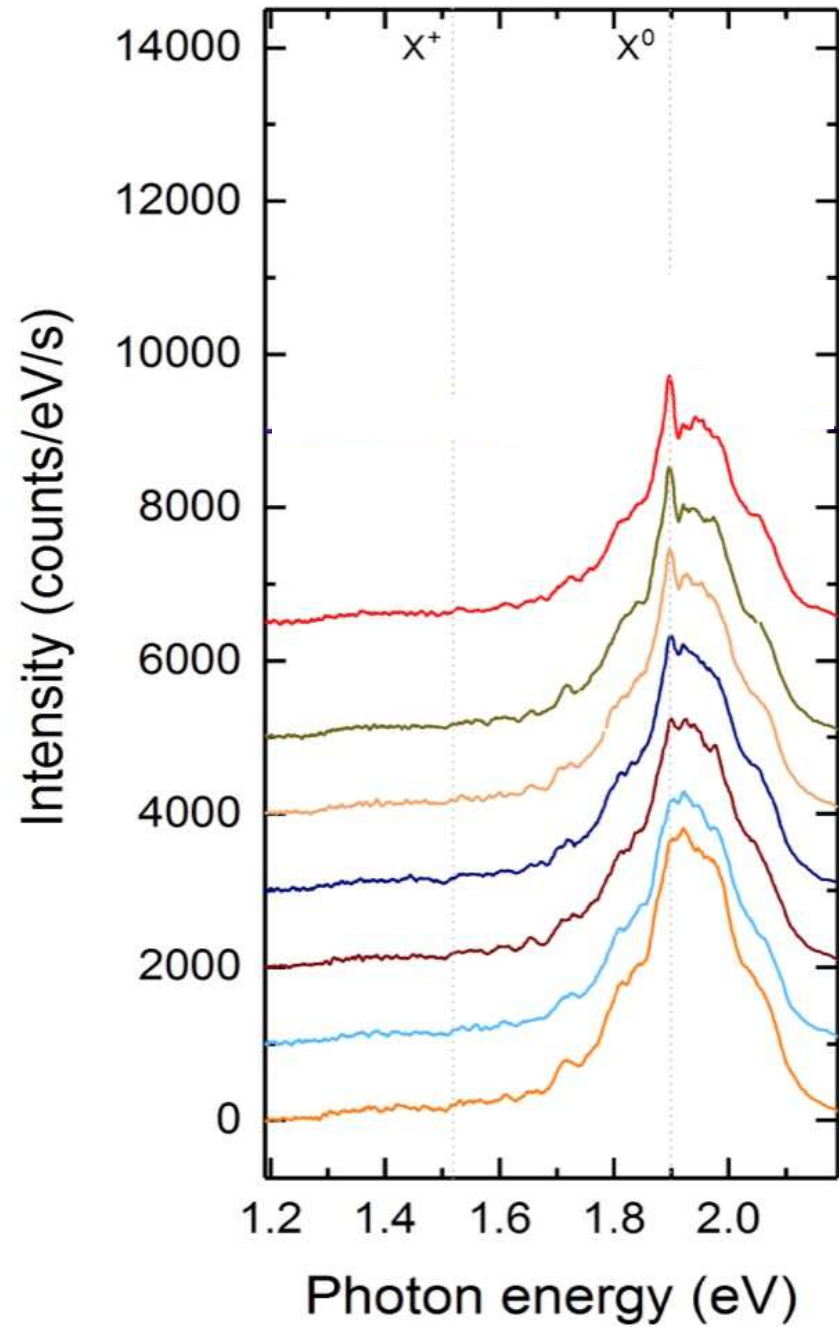
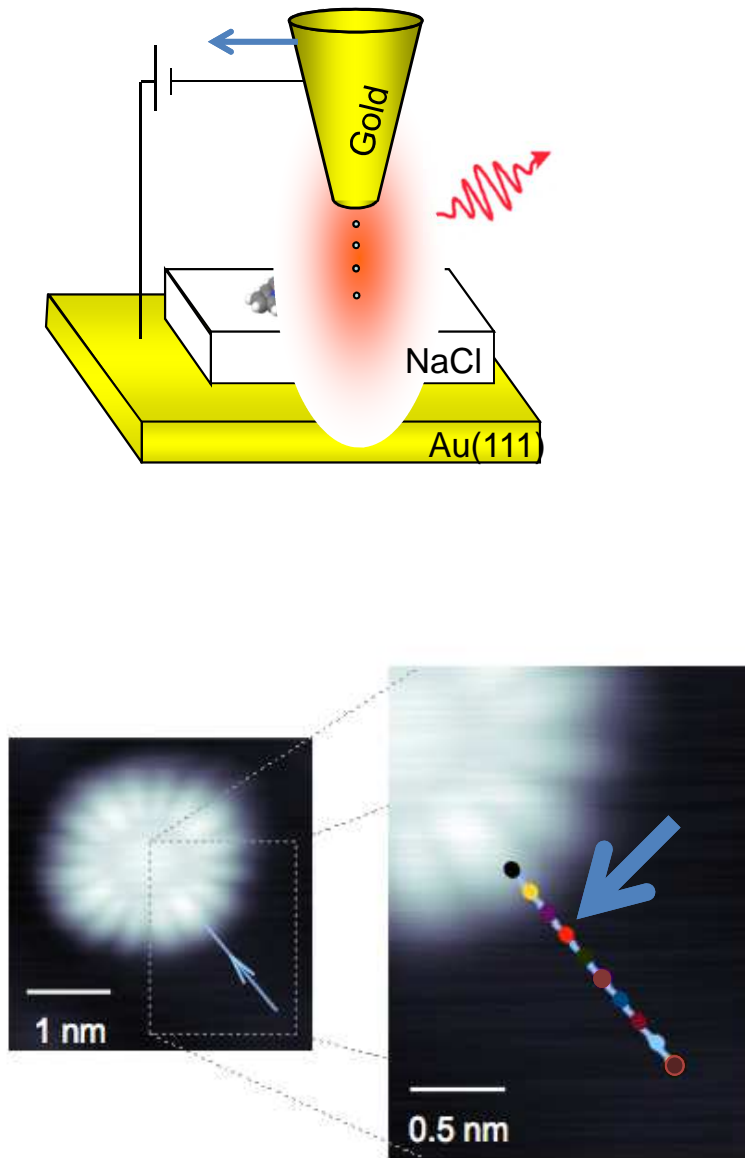

Fluorescence of a charged molecule ?

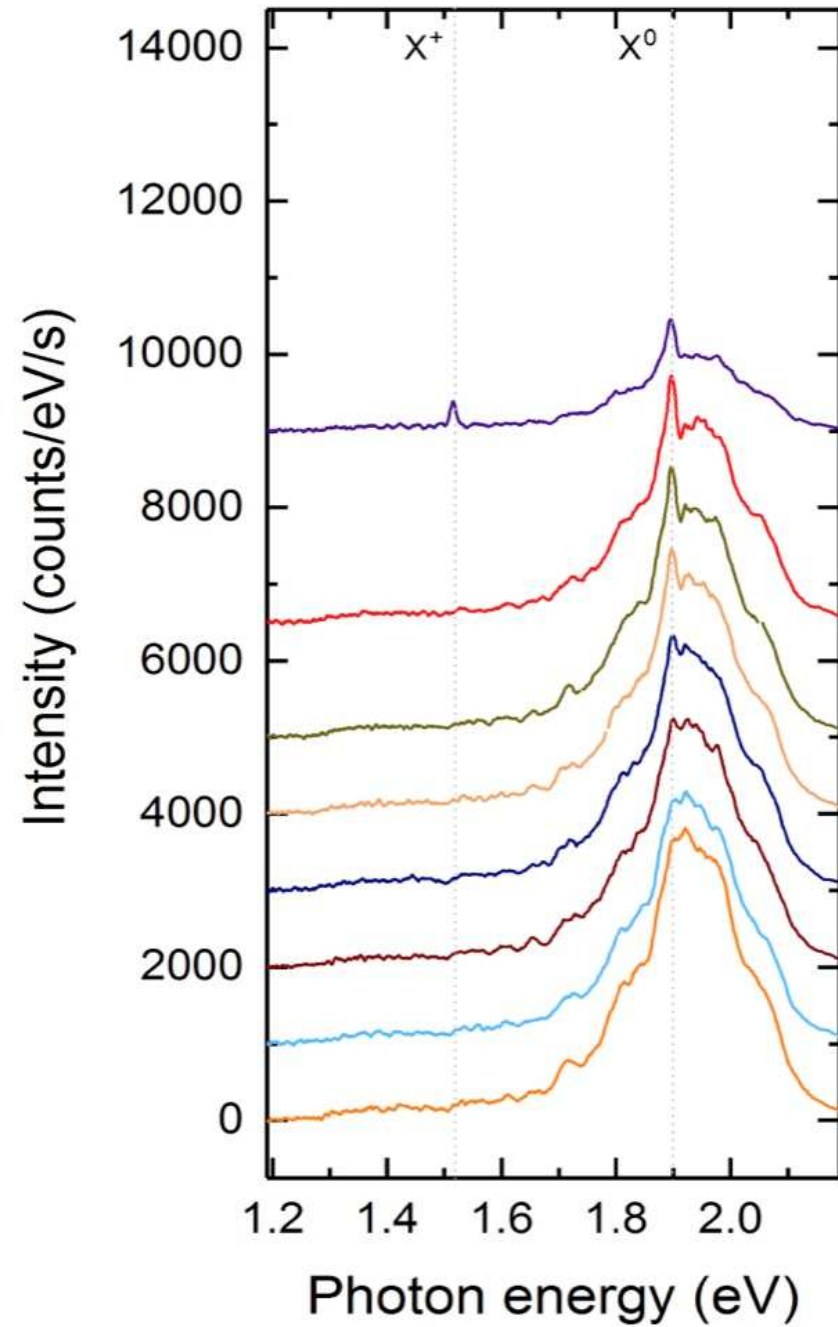
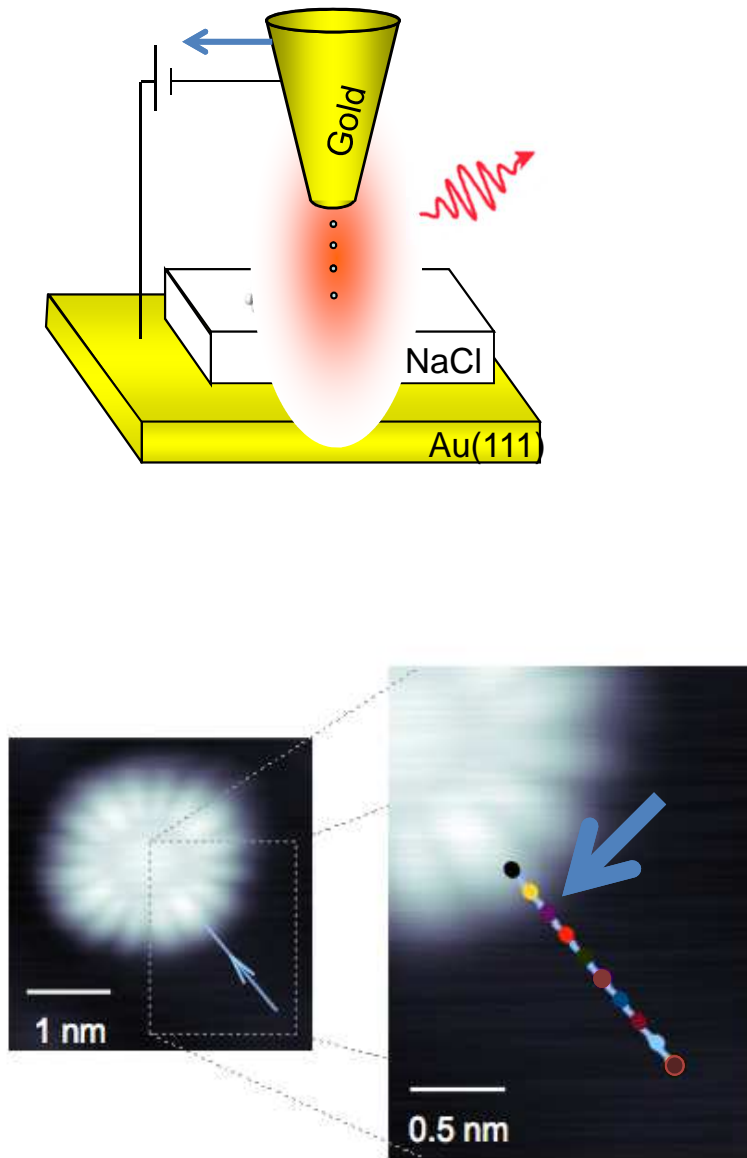

Fluorescence of a charged molecule ?

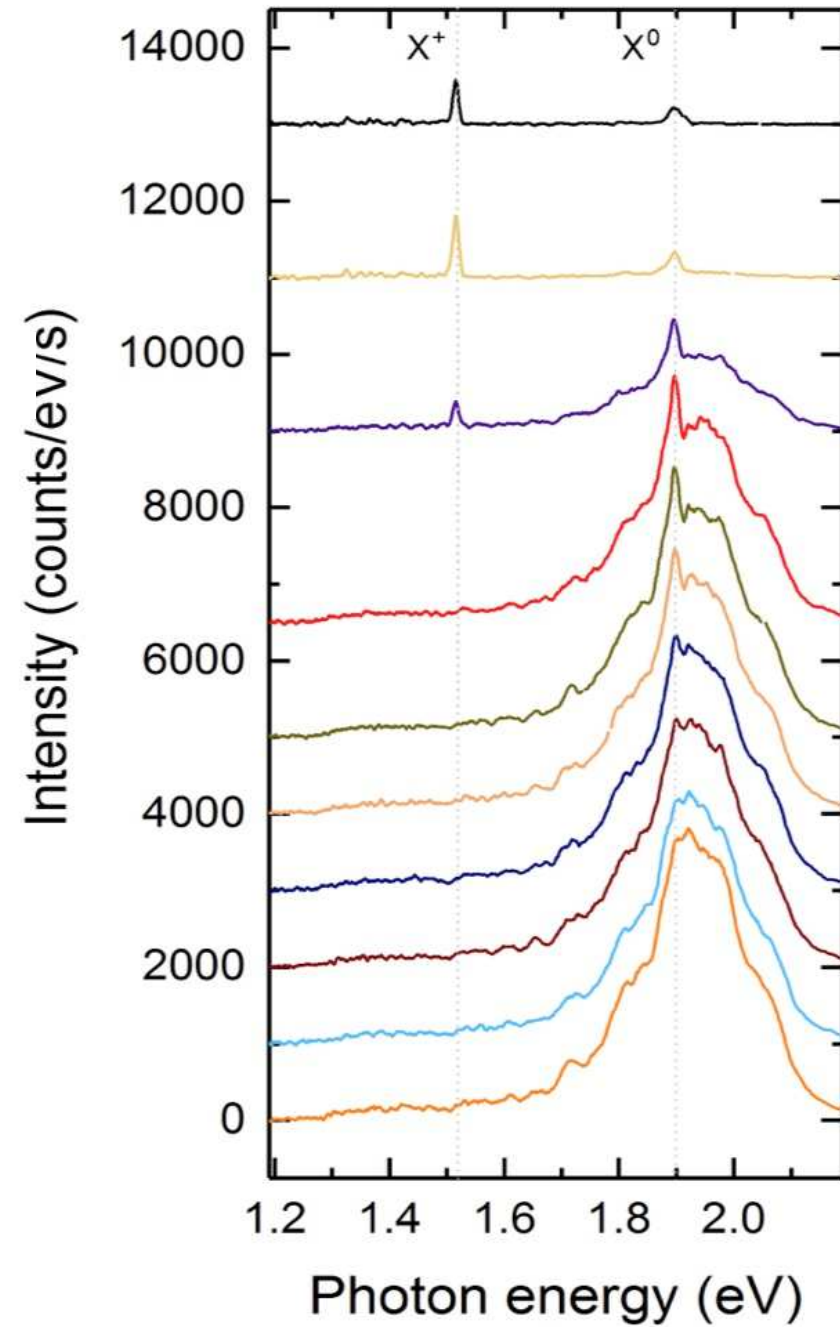
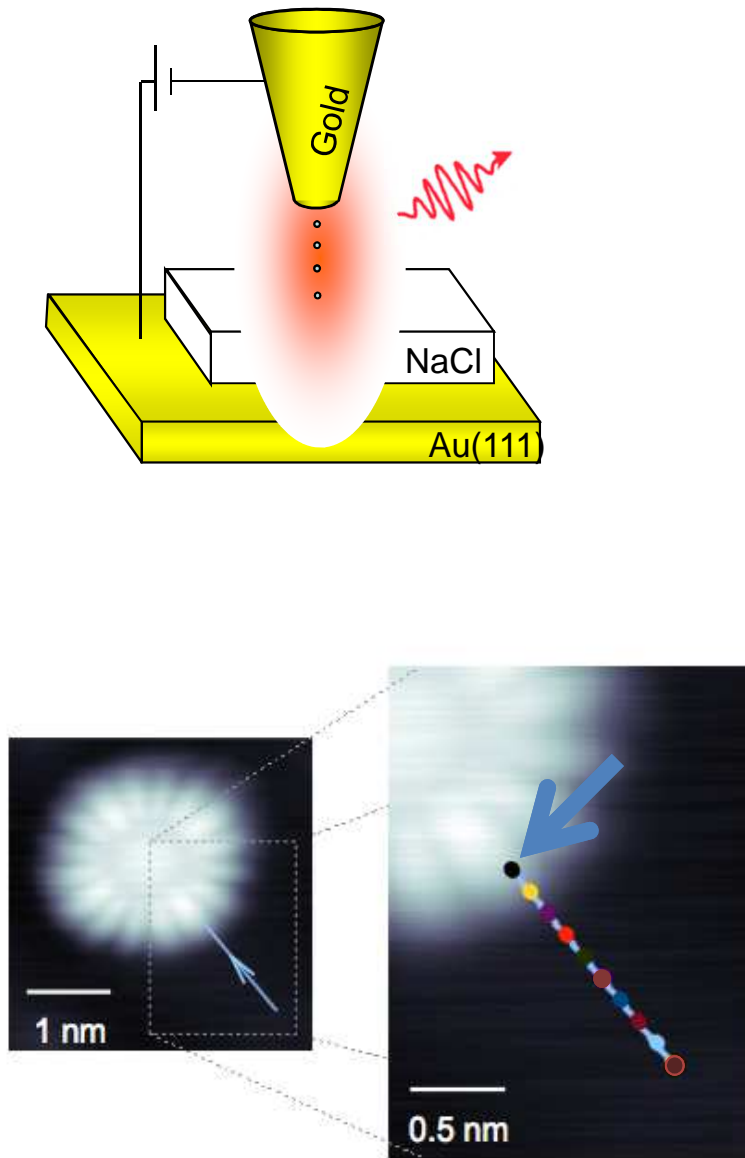

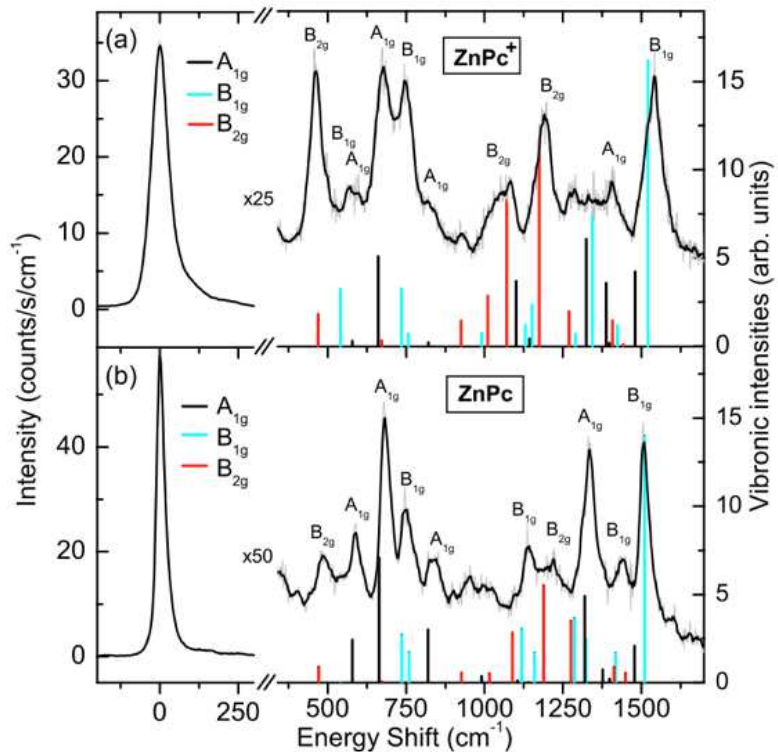

Vibronic fingerprint of the two redox states

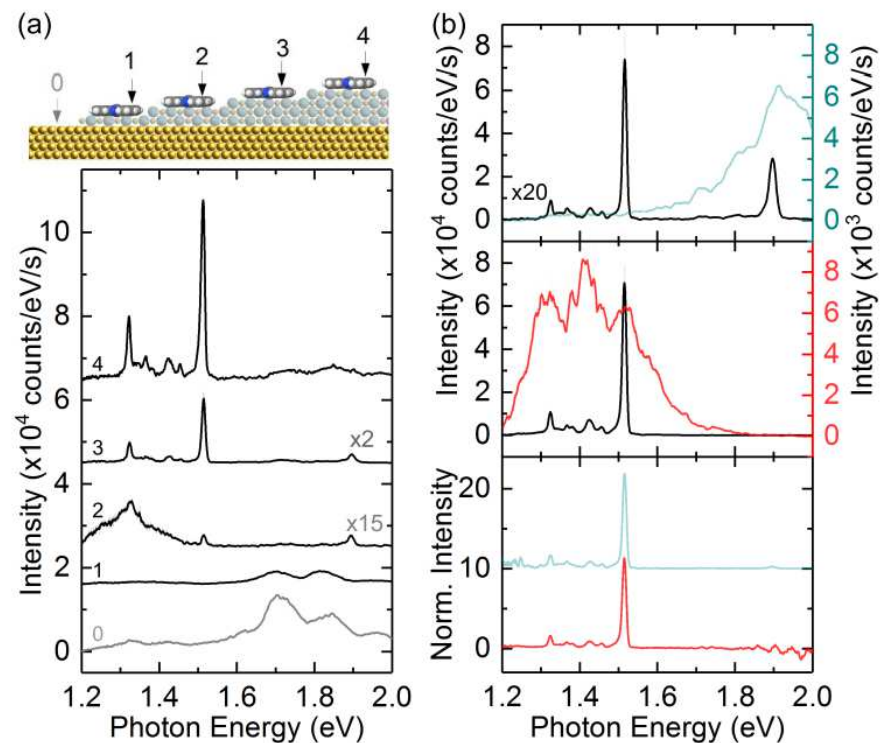

Controlling the respective emission intensity of the two redox states

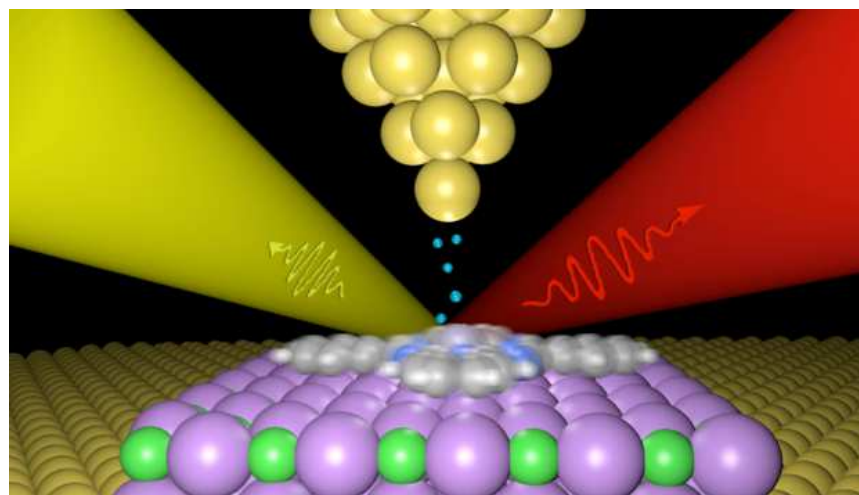

Electrofluorochromism at the single-molecule level

Single molecule spectroscopy with atomic-scale resolution ?

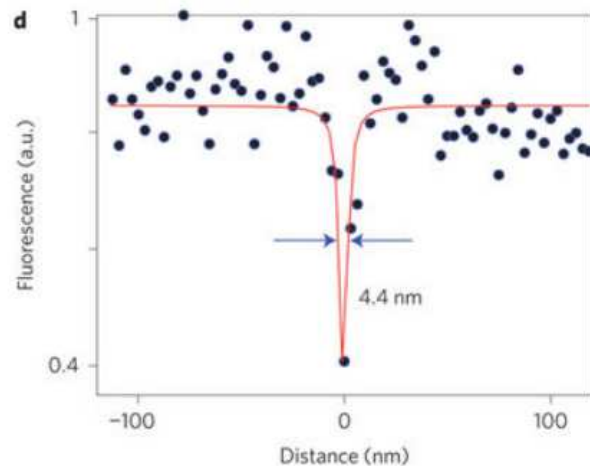
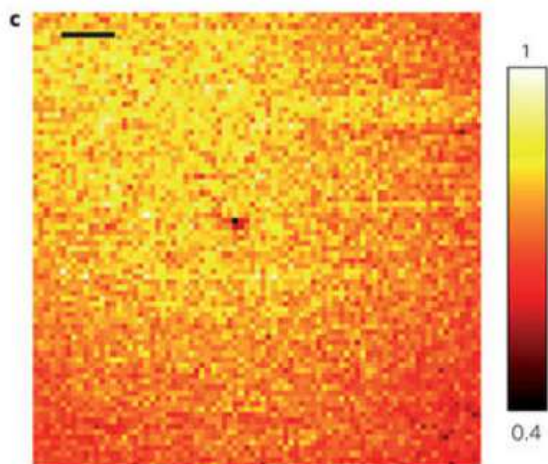

Nature Photonics 9, 658–662 (2015)

Super-resolved fluorescence microscopy:

best spatial resolution ~ 10 nm

Going beyond this limit
with STM-LE

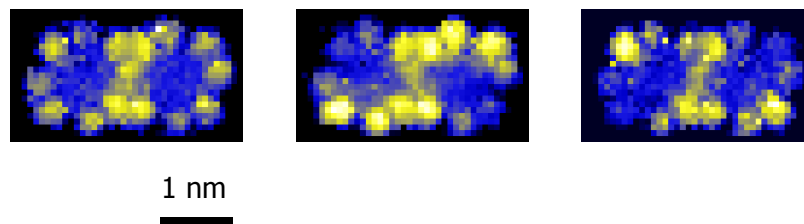
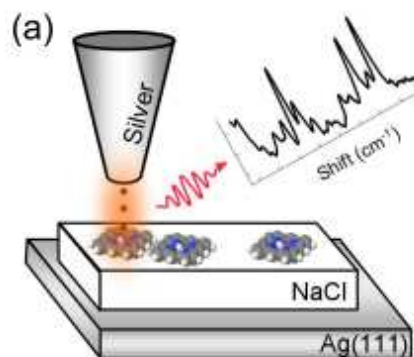

What do we learn ?

- Optical spectroscopy with sub-molecular resolution
- Single-molecule electrofluorochromism
- Dipole-dipole interactions
- Atomic-scale physics of quantum sources

Supported by :



Thank You !!

