



Animation mécanisée de larynx humains excisés

Animaglotte

Thierry LEGOU, Aude LAGIER, Fabrice SILVA, Thomas HELIE, Djellal CHALABI, David ROZE, Antoine GIOVANNI

Le conduit vocal – aspects acoustiques

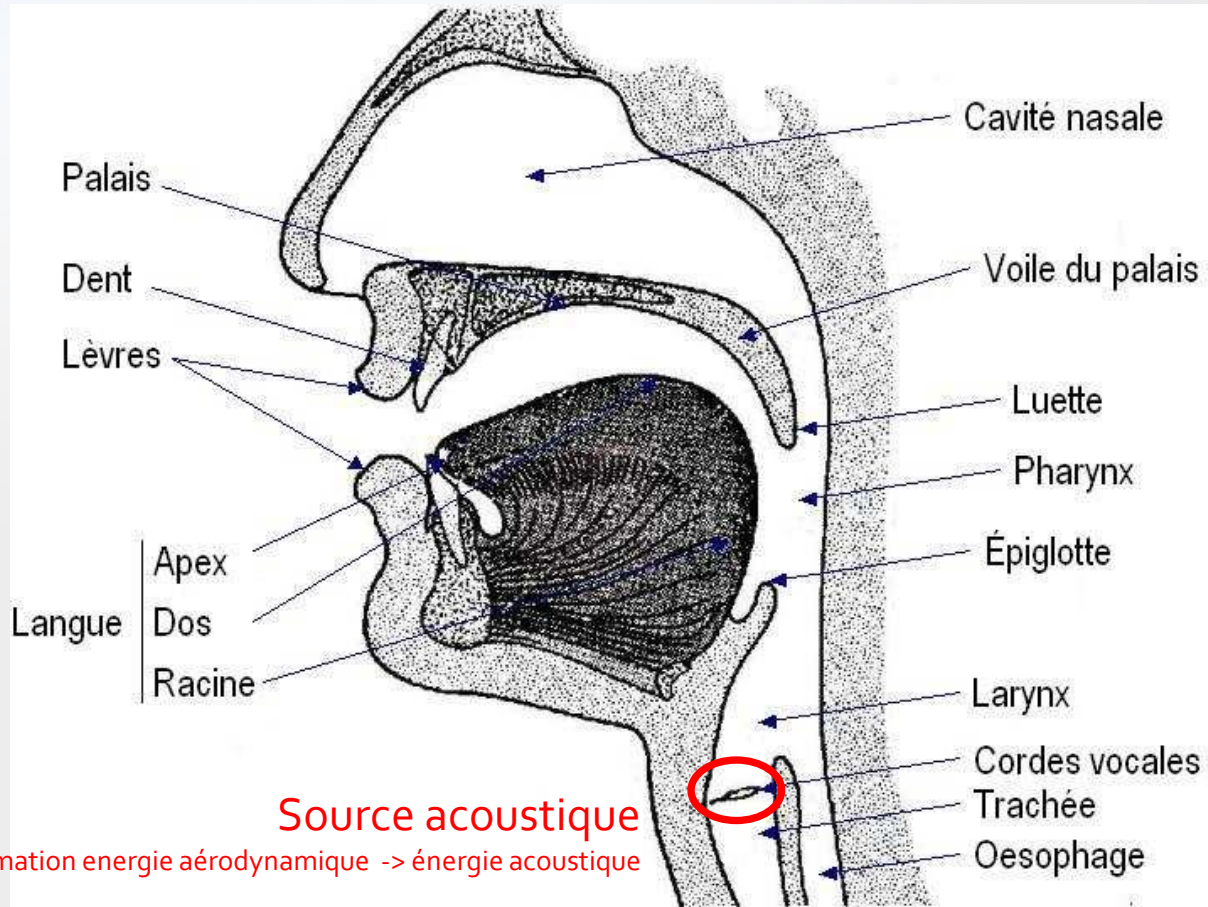

Le conduit vocal – aspects acoustiques

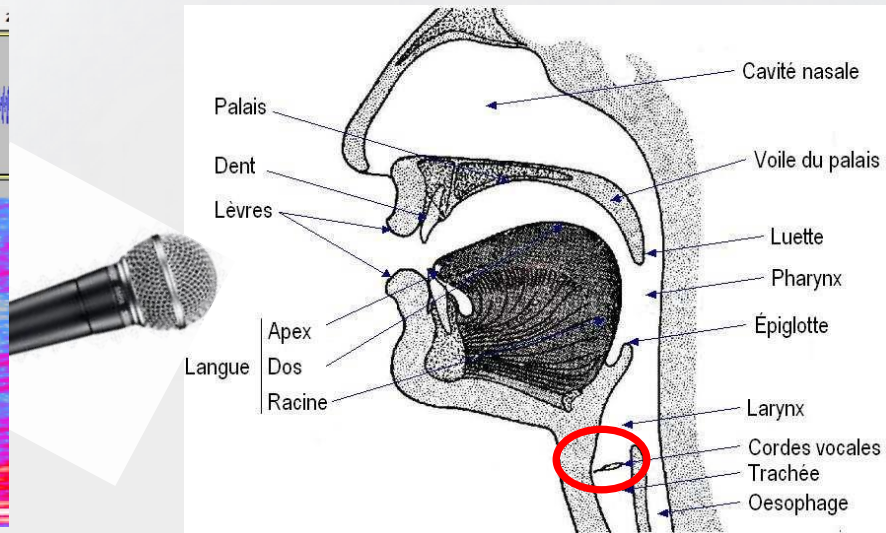
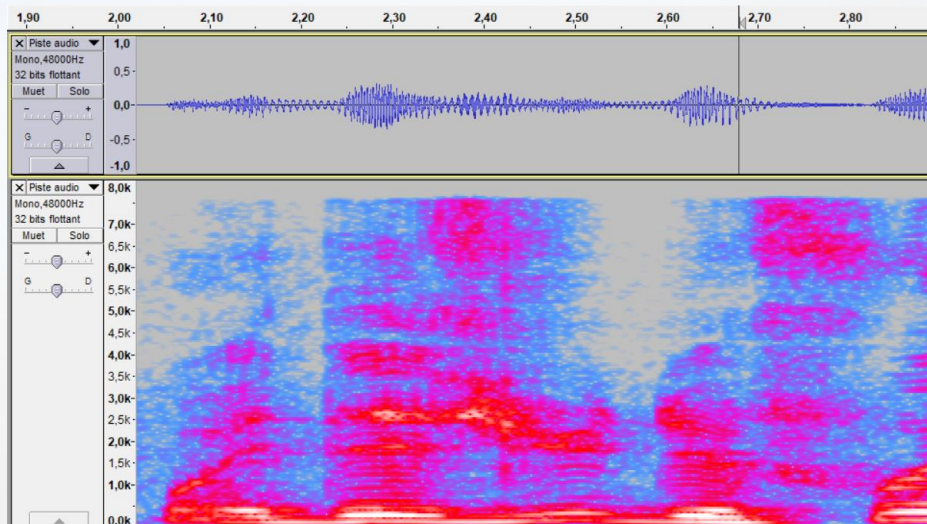

La production de la parole s'appuie sur une activité musculaire complexe
Différents articulateurs (masse, structure, mouvements)

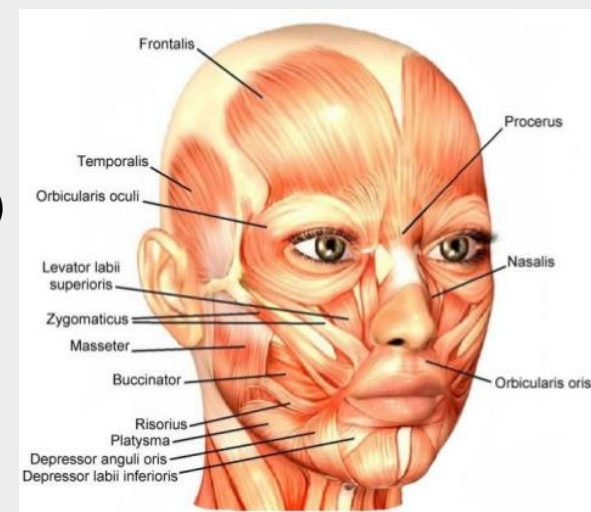

Le conduit vocal – les résonateurs acoustiques

● M

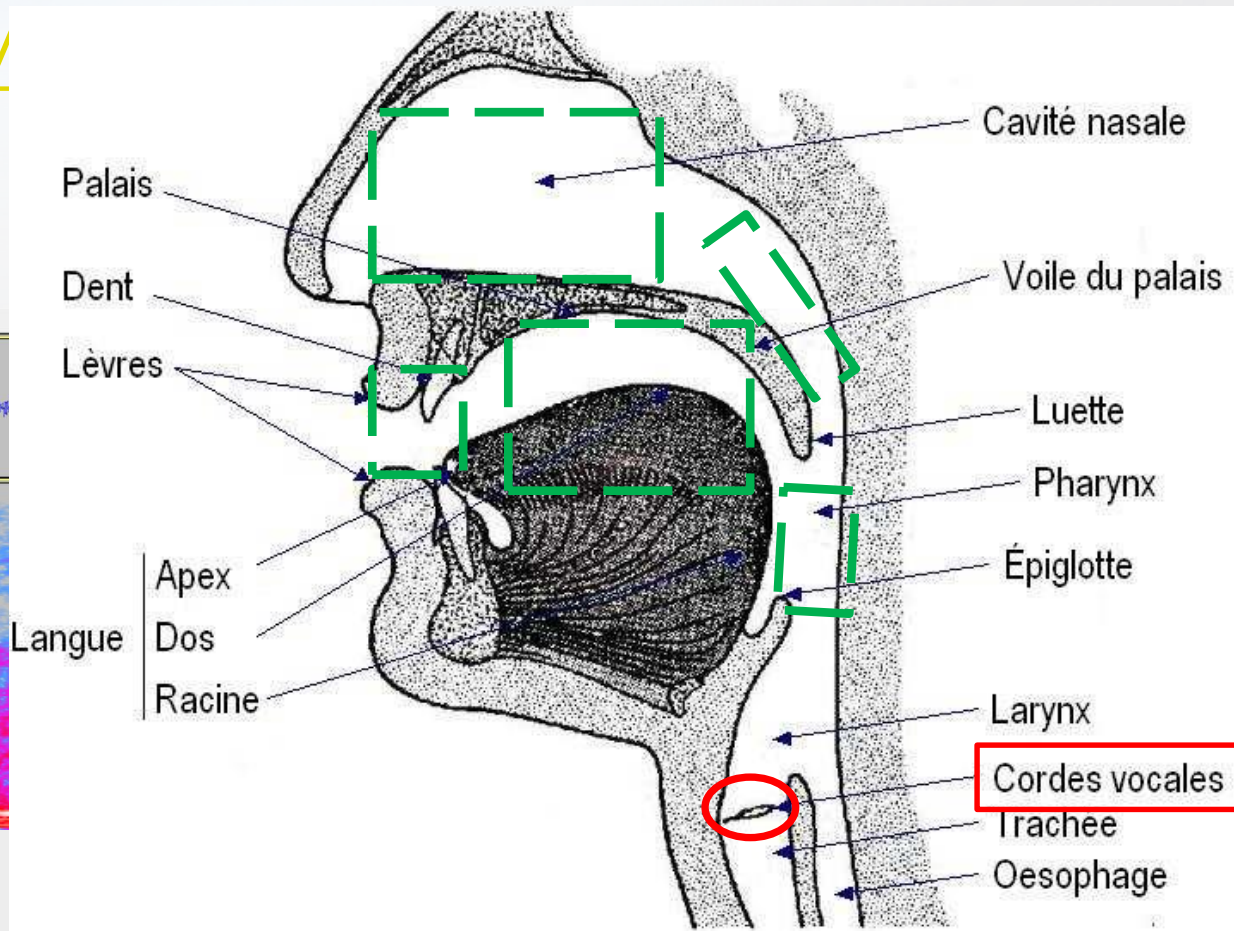

Résonateurs
acoustiques

Ces résonateurs **acoustiques**, modifient le signal de la source, ils jouent le rôle de **filtres acoustiques**

<C:\THIERRY\SFP\MECAVIVANT\Motormouth Robot KTR-2 - Full Original Video.mp4>

Les plis vocaux

- Two mass model – damping

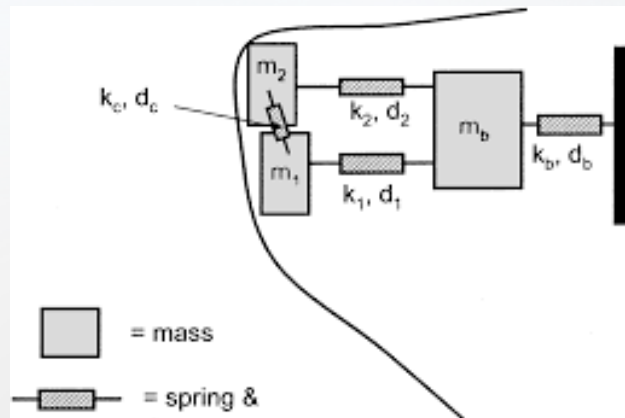
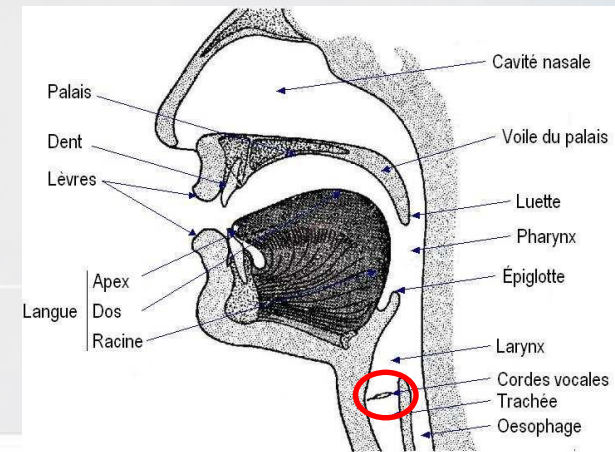

BACK



FRONT

Des Meures invivo...



- ..\..\BANC_LARYNX\ANIMAGLOTTE\videos larynx normaux\demo.mp4

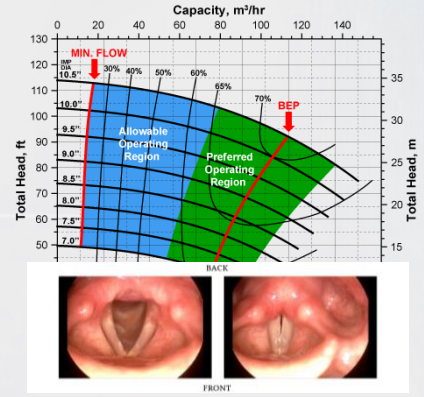
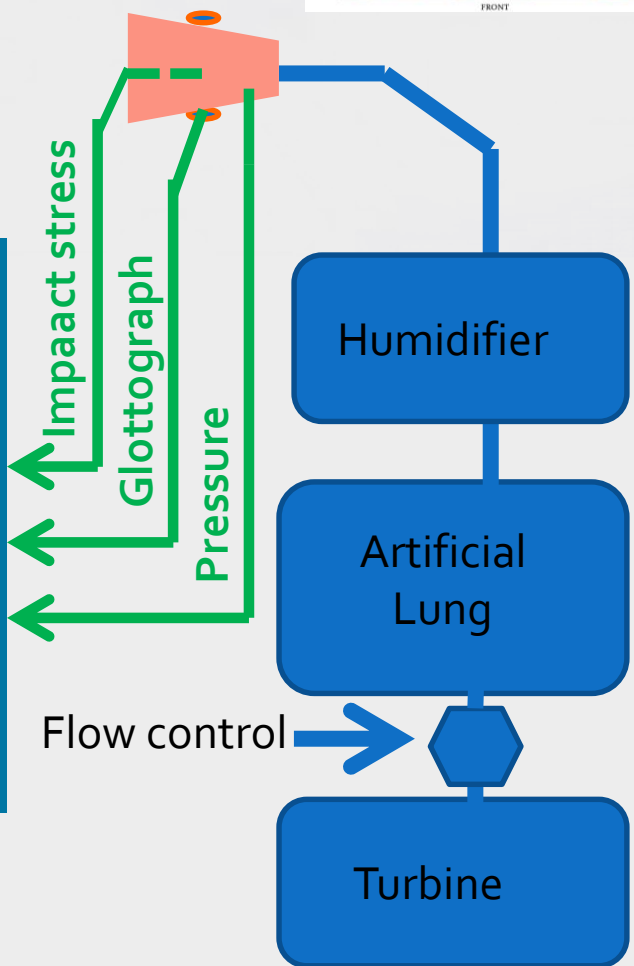
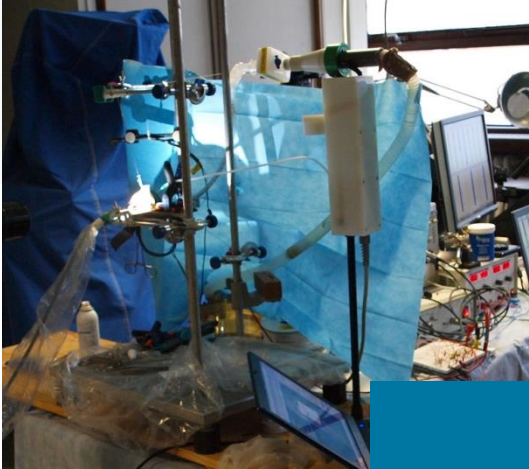
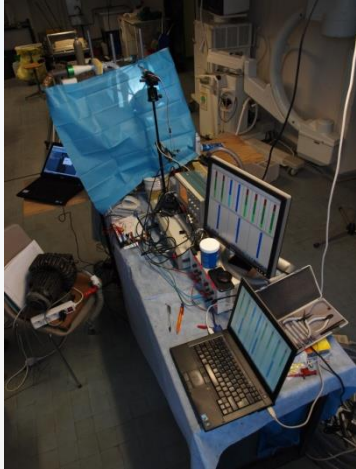

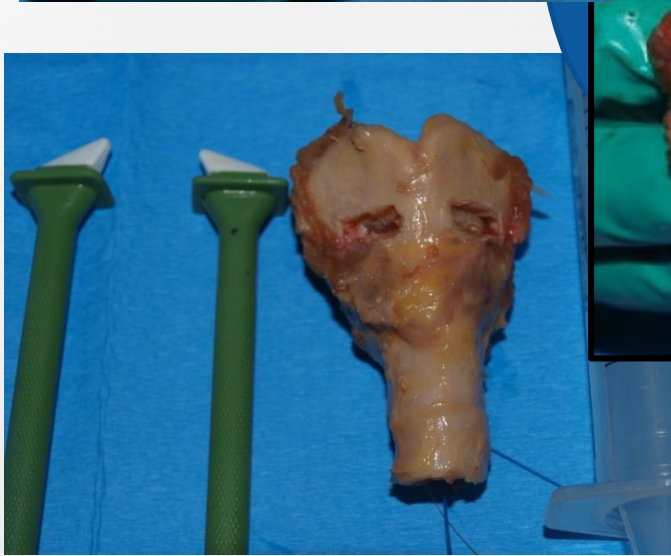
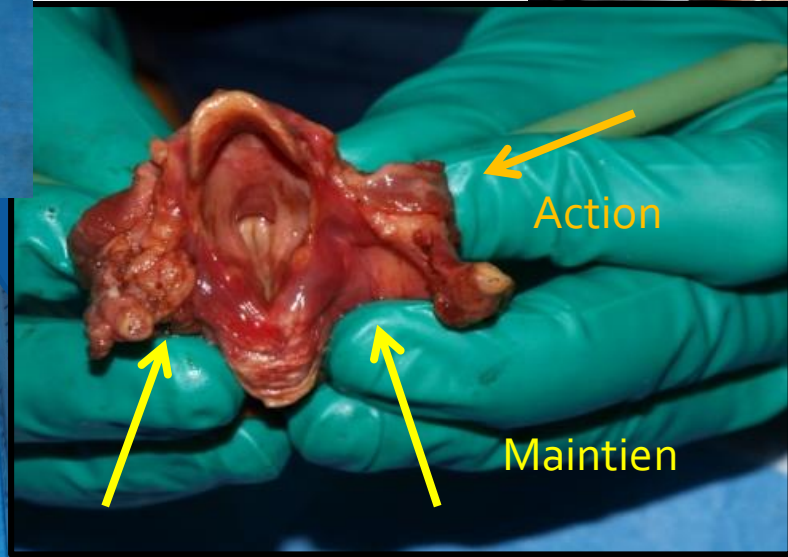
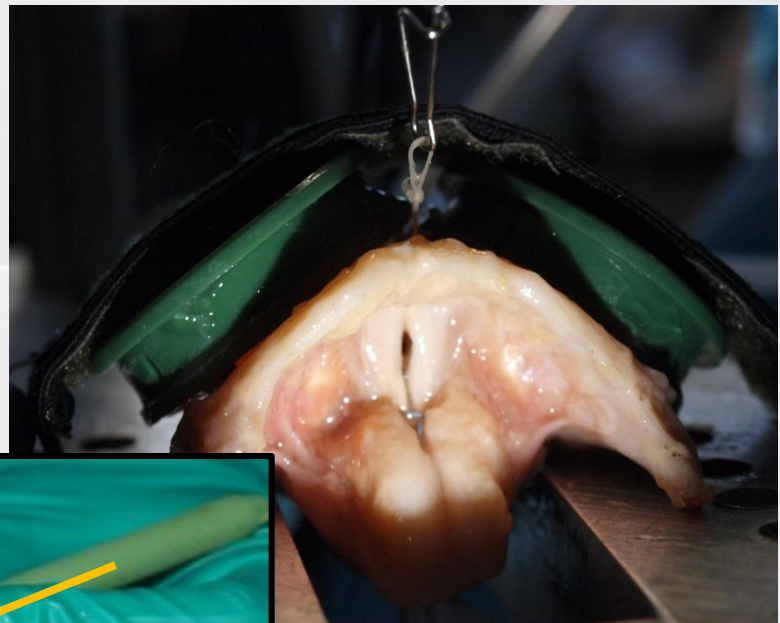

Idée directrice du projet:

Développer un système mécanisé d'animation pour des larynx humains excisés

Approche / Méthode:

Après avoir mesuré in vivo la dynamique (amplitude et vitesse) de la glotte

->reproduire par un contrôle mécanique artificiel cette dynamique

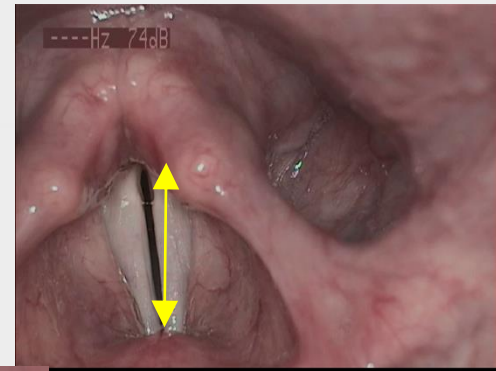
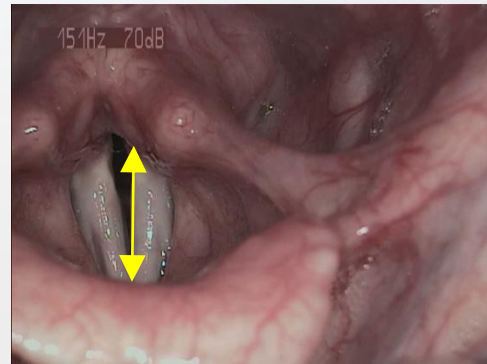
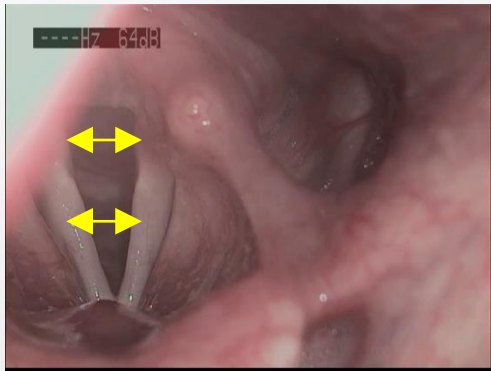

Contrôle Mécanisé

- Contrôler la configuration du plan glottique pour:
 - Position pré-phonatoire (pour point de fonctionnement réaliste)
 - Introduction possible d'asymétries
 - Mesure de l'effet de l'aire glottique sur phonation (onset /offset de phonation, pression transglottique,...)
 - Etude de différents types/modes de phonation
 - Fry, chuchotement, coup de glotte,.....

Les muscles Laryngés Intrinsèques

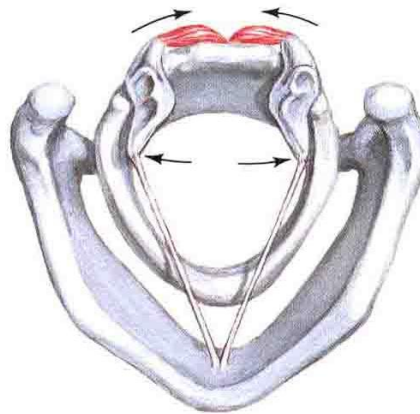

Action of posterior cricoarytenoid muscles
Abduction of vocal folds

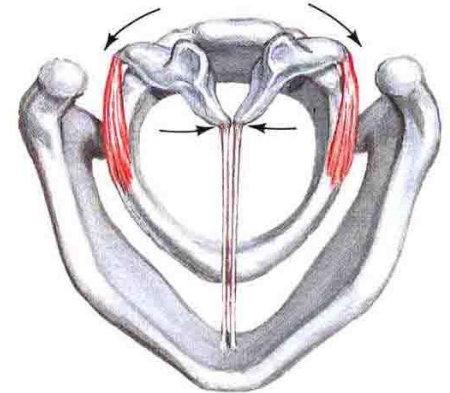

Action of lateral cricoarytenoid muscles
Adduction of vocal folds

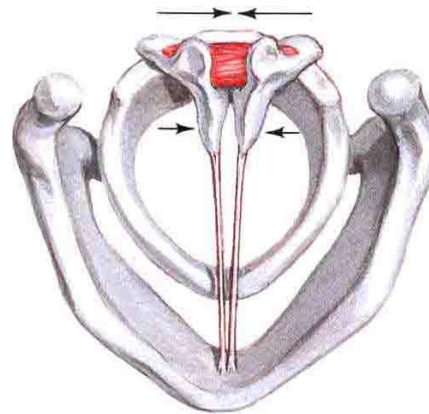

Action of transverse arytenoid muscle
Adduction of vocal folds

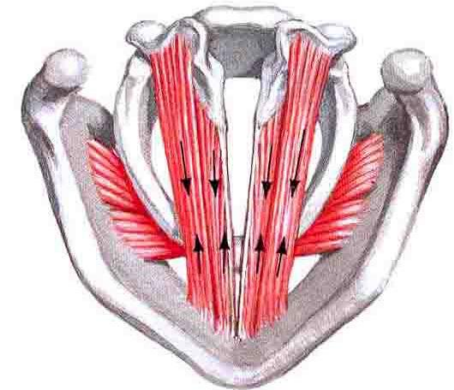

Action of vocalis and thyroarytenoid muscles
Shortening (relaxation) of vocal folds

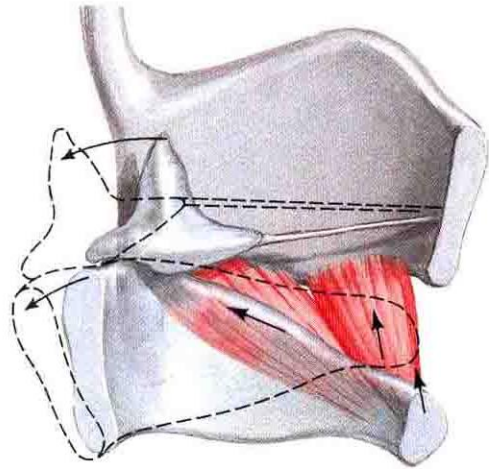

Action of cricothyroid
Lengthening (tension)

➔ reproduire les différentes configurations laryngées

Actions appliquées aux larynx possiblement différentes des conditions « naturelles »

Les muscles Laryngés Intrinsèques

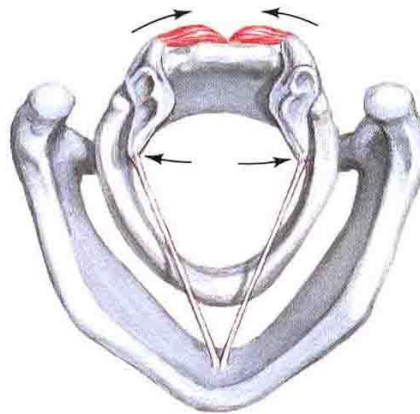

Action of posterior cricoarytenoid muscles
Abduction of vocal folds

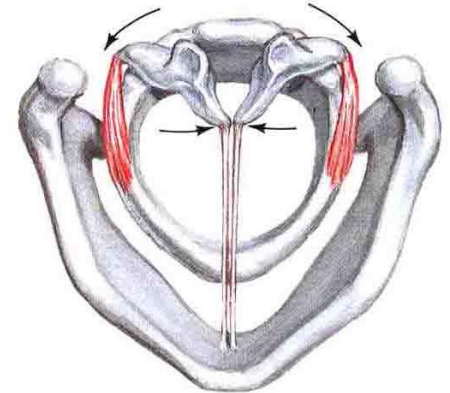

Action of lateral cricoarytenoid muscles
Adduction of vocal folds

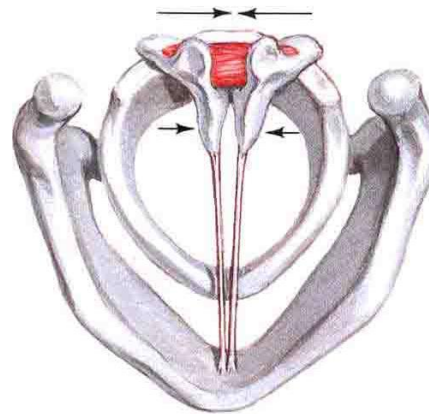

Action of transverse arytenoid muscle
Adduction of vocal folds

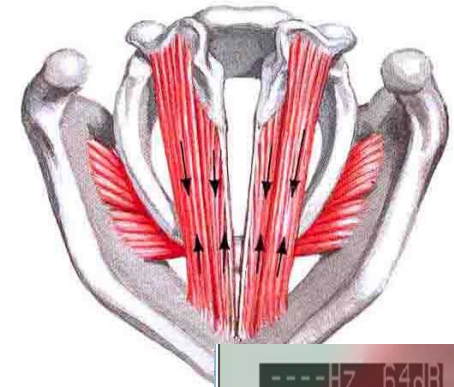

Action of vocalis and
Shortening (relaxation)

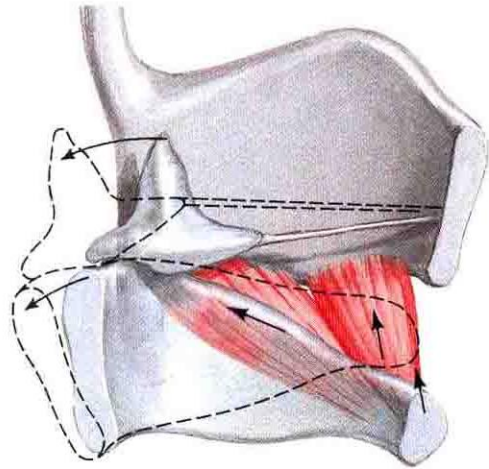

Action of cricothyroid muscle
Lengthening (tension)

→ reproduire les différentes configurations laryngées

Actions appliquées aux larynx possiblement différentes des conditions «
L'objectif est la reproduction des géométries de glottes

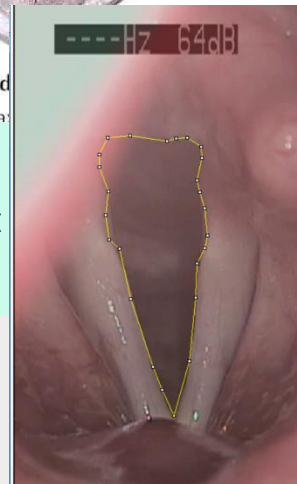

La bascule CT

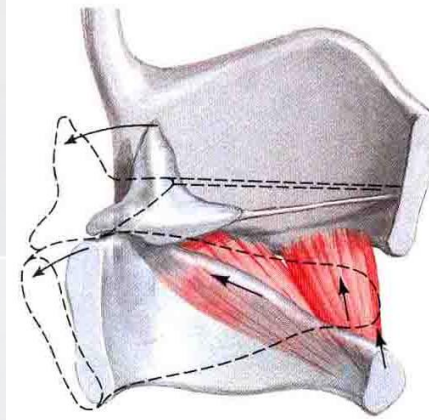

Action of cricothyroid muscles
Lengthening (tension) of vocal folds

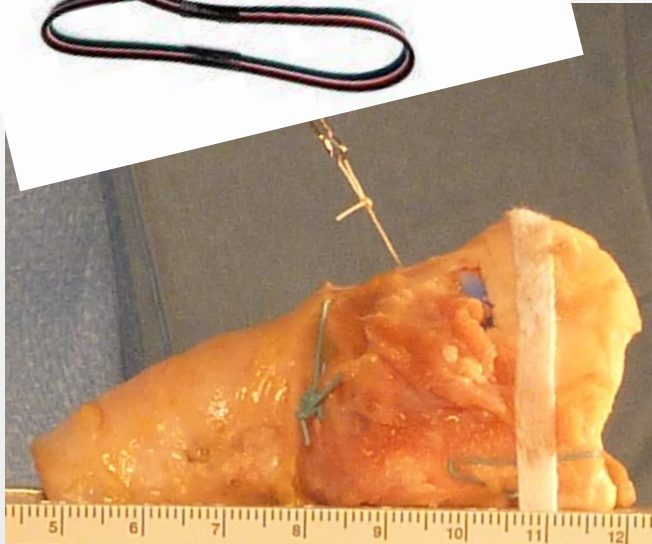

> Tension + Elongation des plis vocaux

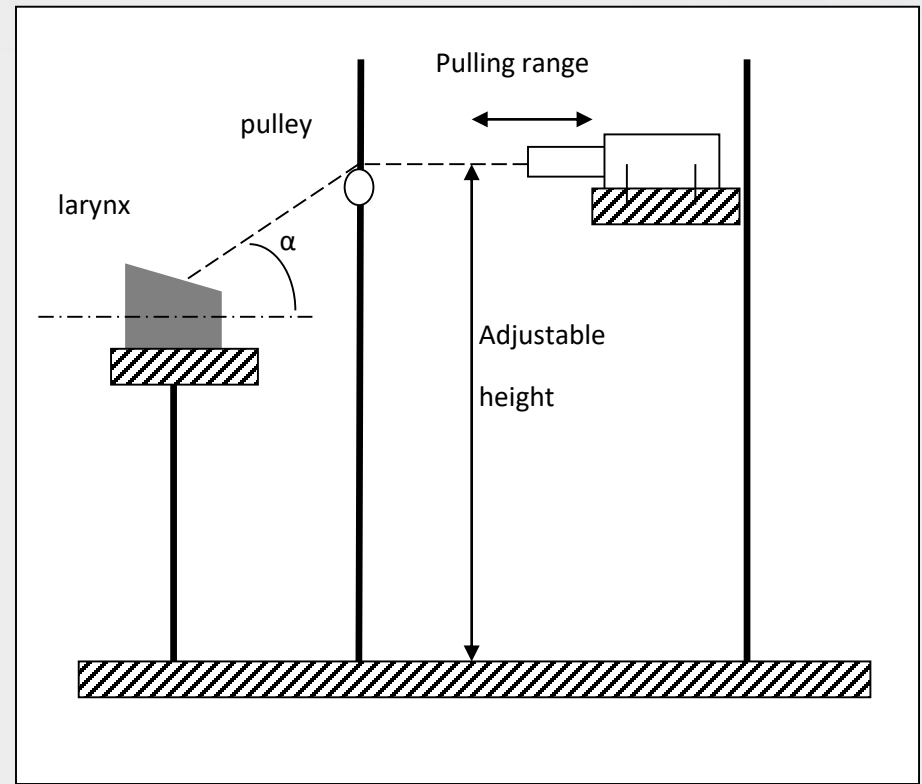

Effets de la bascule CT

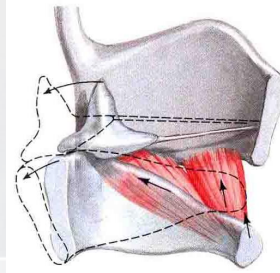

Action of cricothyroid muscles
Lengthening (tension) of vocal folds

Effect on Lengthening and tension of Vocal Folds

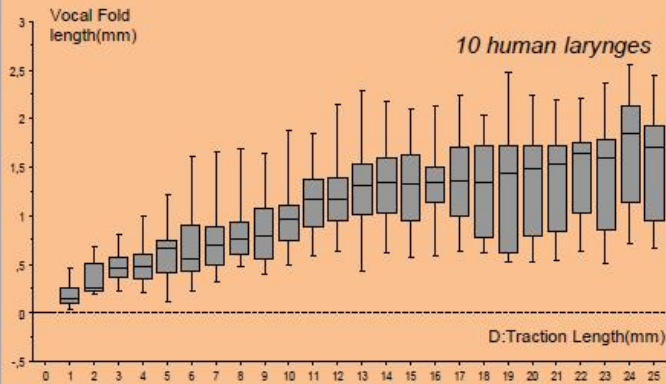

Effect onto Phonation

Multi 1mm step series
traction and release

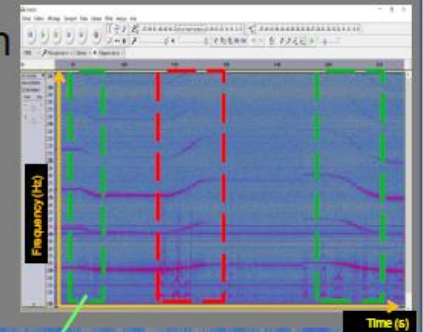
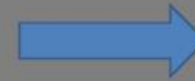

4 mm loose – step 1mm

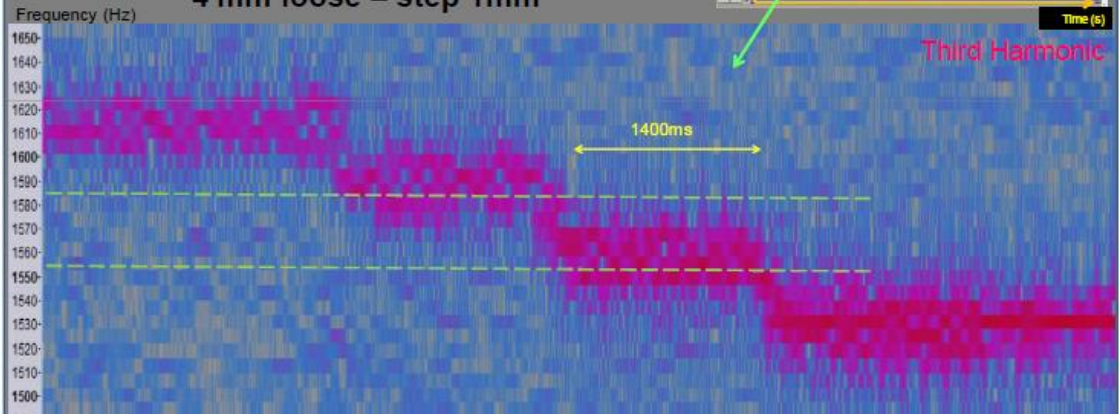

Actionneurs

Les servo-moteurs



Masse tractée/poussée Maxi : 700g
Répétabilité $\approx 1,2\text{mm}$

Actionneurs – le servomoteur



C'est la **durée de l'impulsion** qui fixe la **position angulaire**

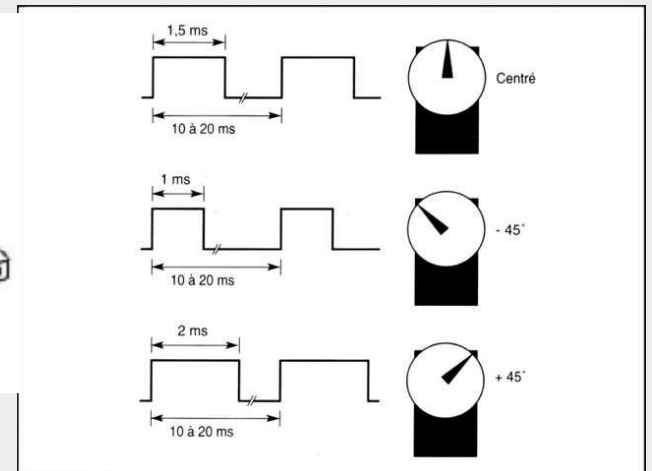
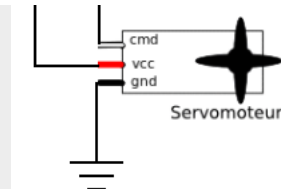
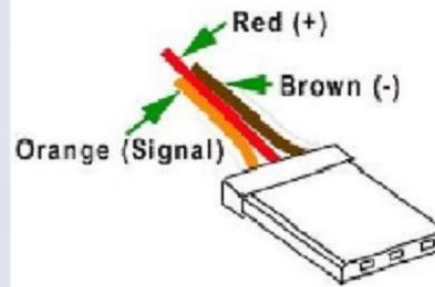

Pour l'Adduction — Antérieure & longitudinale

Utilisation d'implants de Montgomery

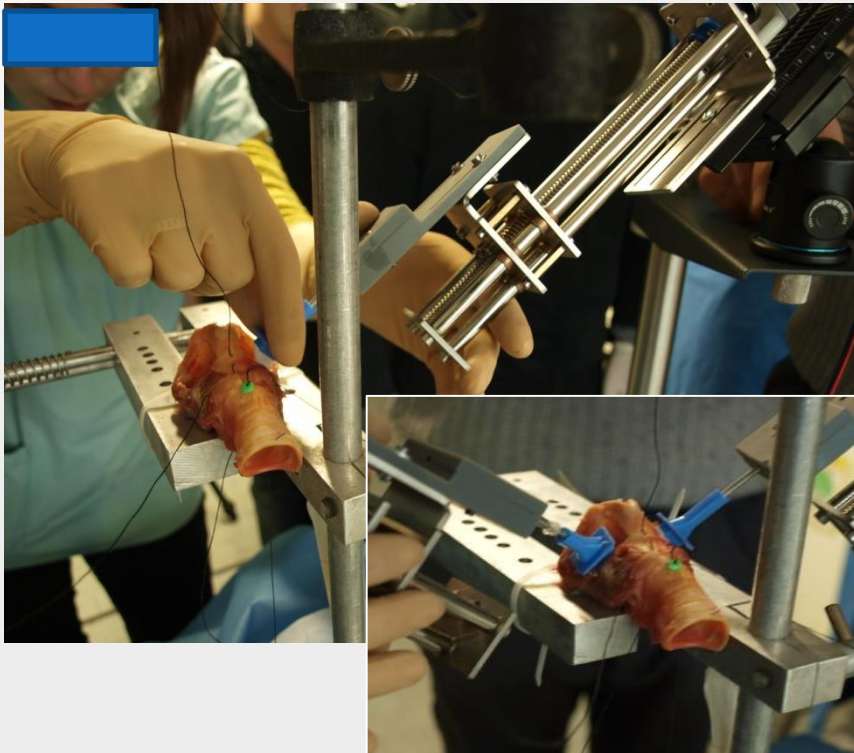
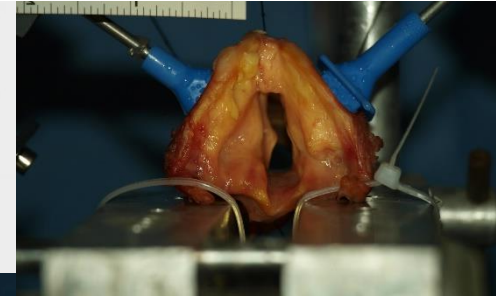
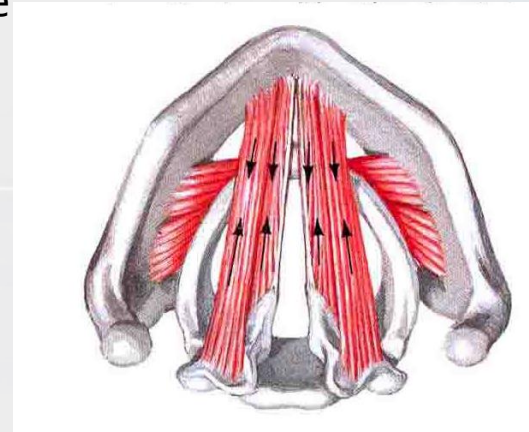
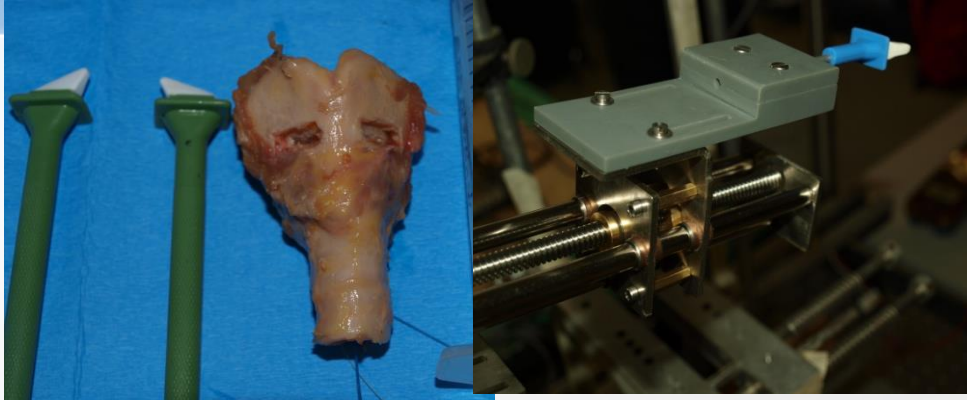

Précision < 200µm

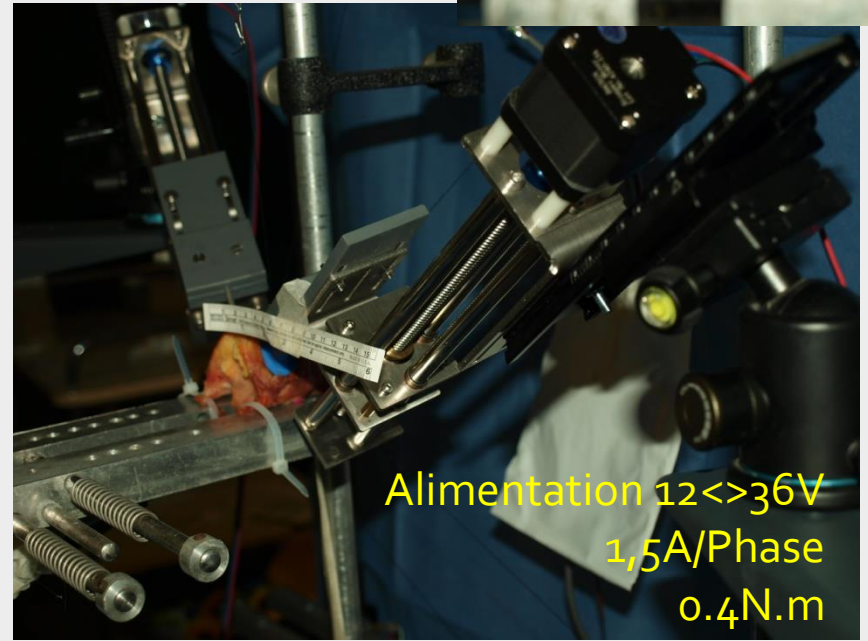

Alimentation 12<>36V
1,5A/Phase
0.4N.m

Commande du

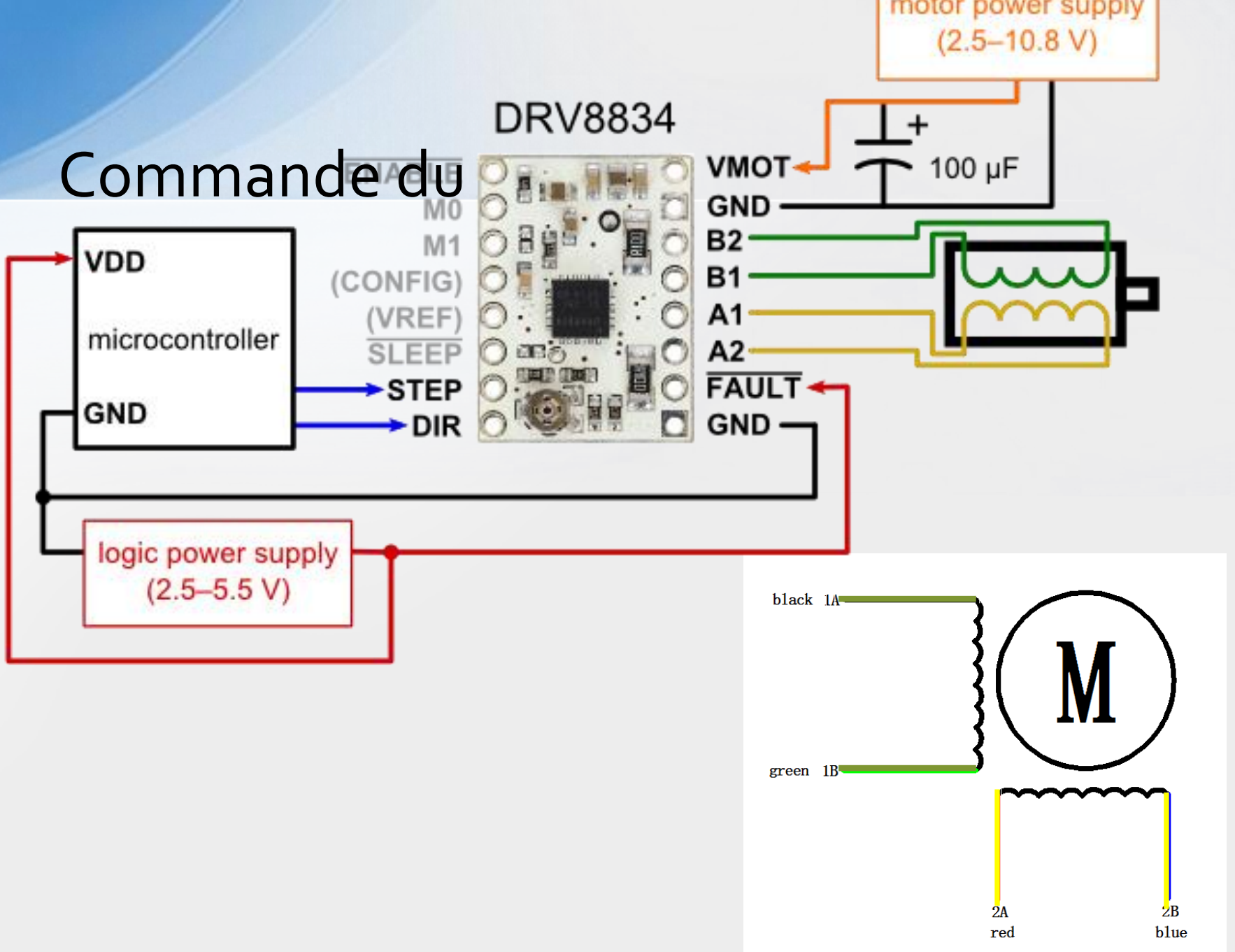

Le mouvement des arythénoïdes

Précision angulaire $< 1^\circ$
Couple de maintien 0,35N.m
Courant de phase 0,9A sous 5V

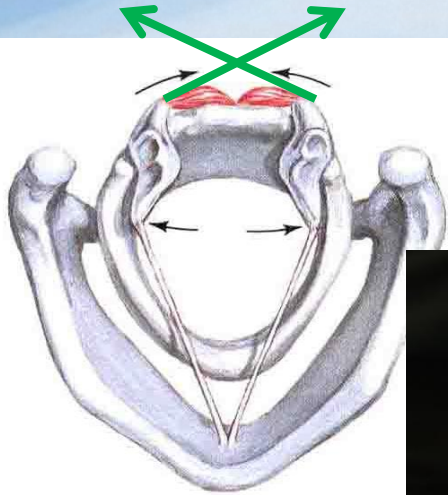

Action of posterior cricoarytenoid muscles
Abduction of vocal folds

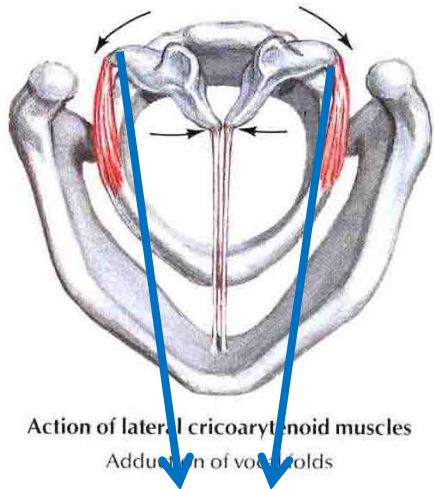

Action of lateral cricoarytenoid muscles
Adduction of vocal folds

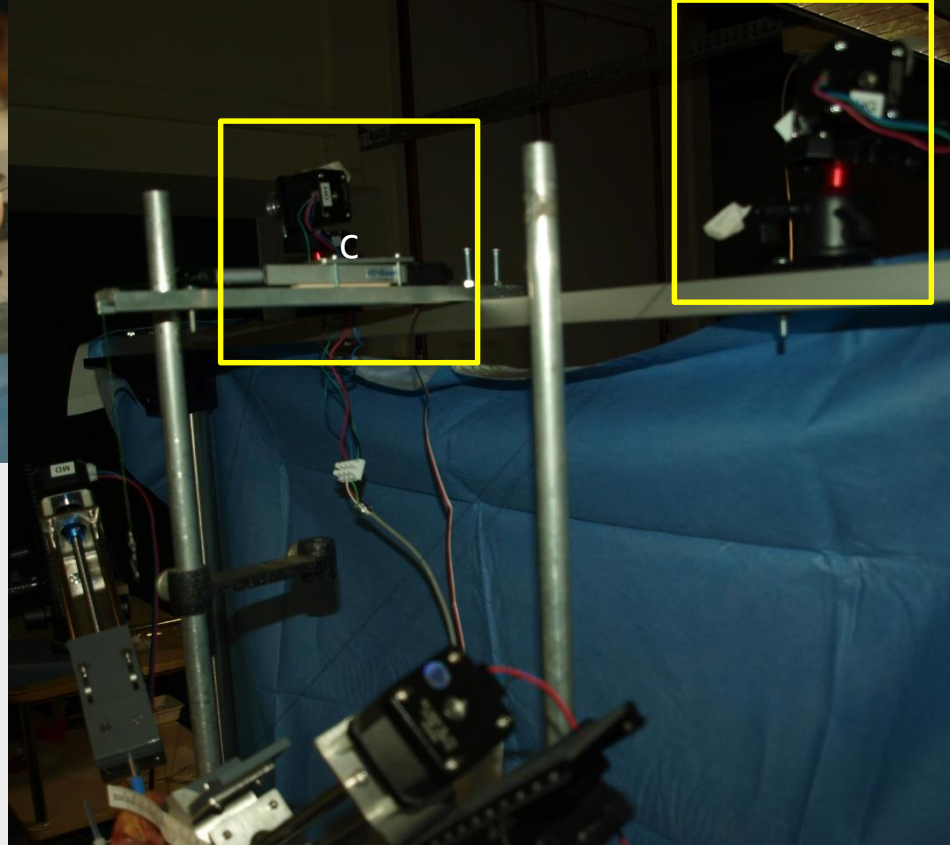
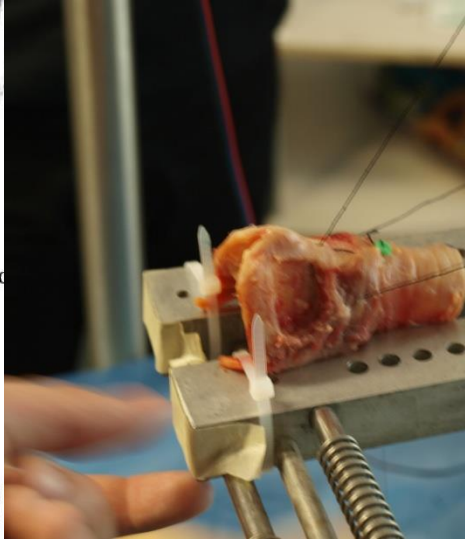

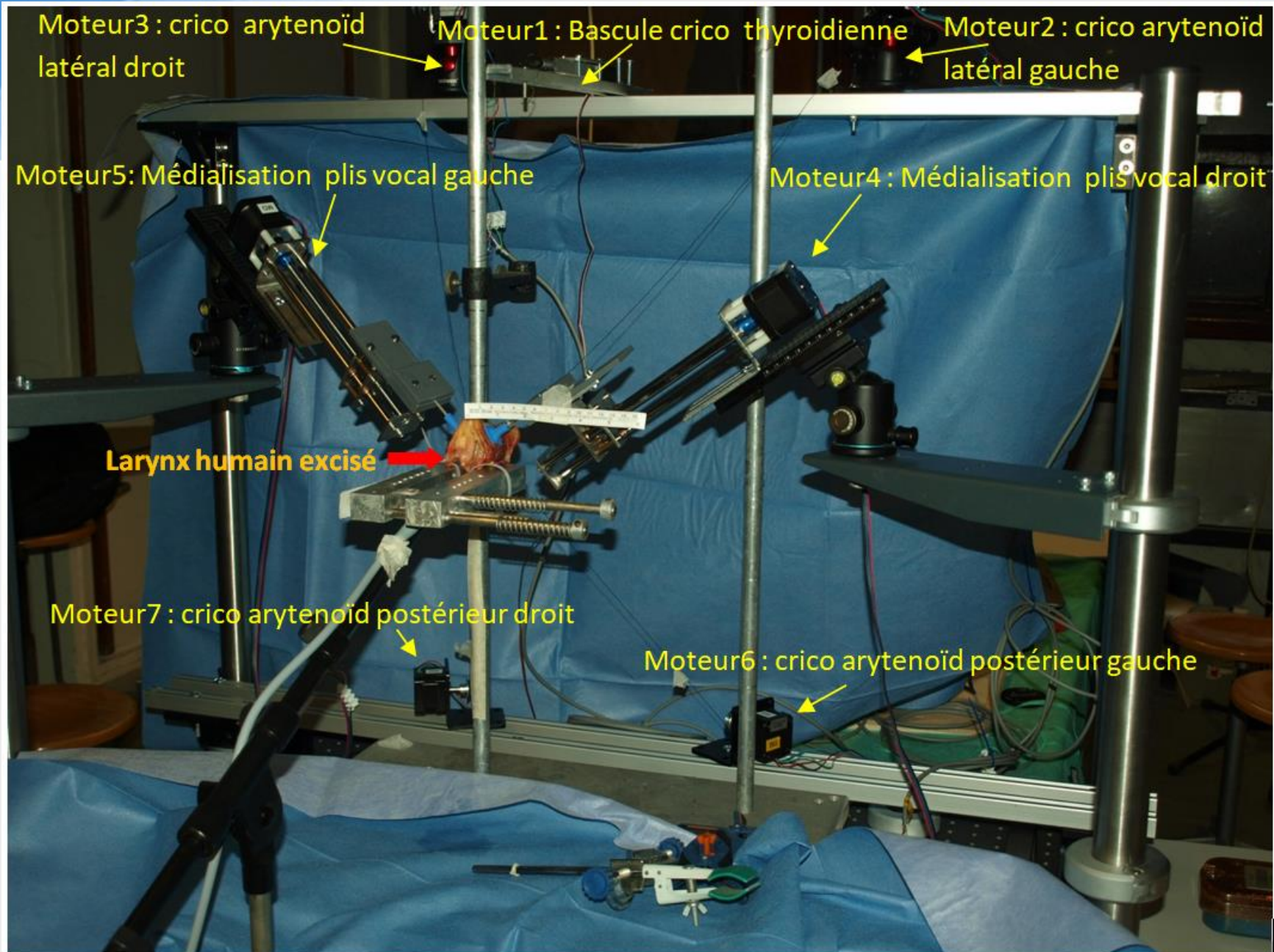

Contrôle du système

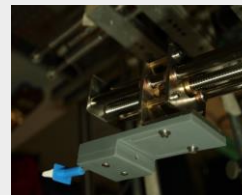
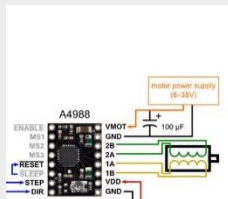
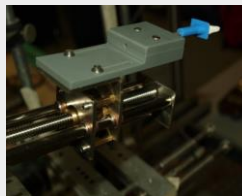
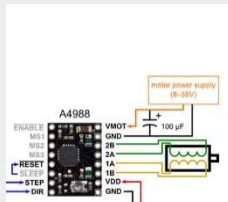
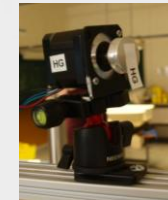
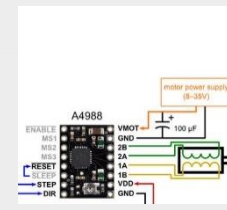
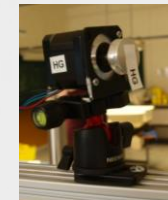
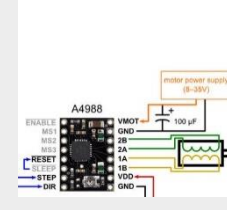
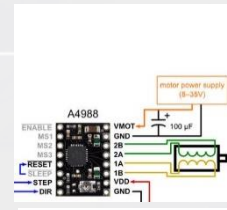
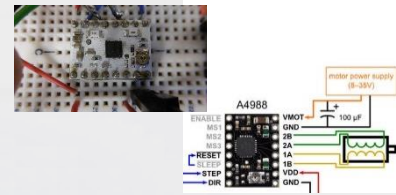
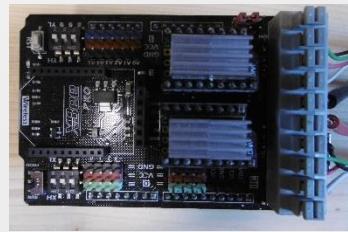
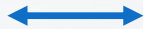
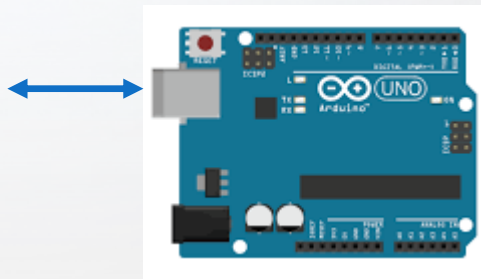

- Pour une distance ou rotation: temps alloué pour se réalisation est déterminé
- > Action définie pour chaque moteur pour chaque pas de temps

Series de commandes

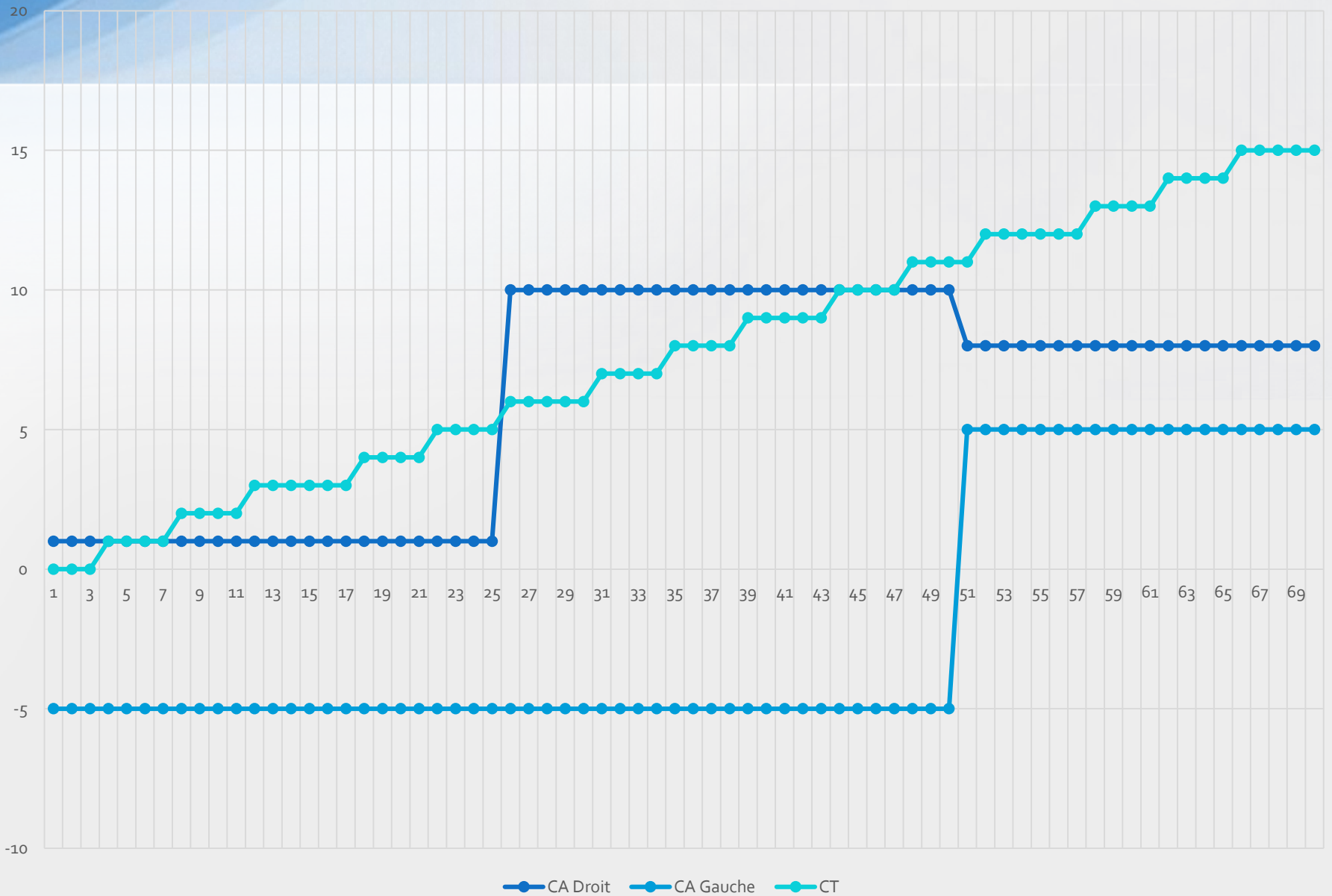

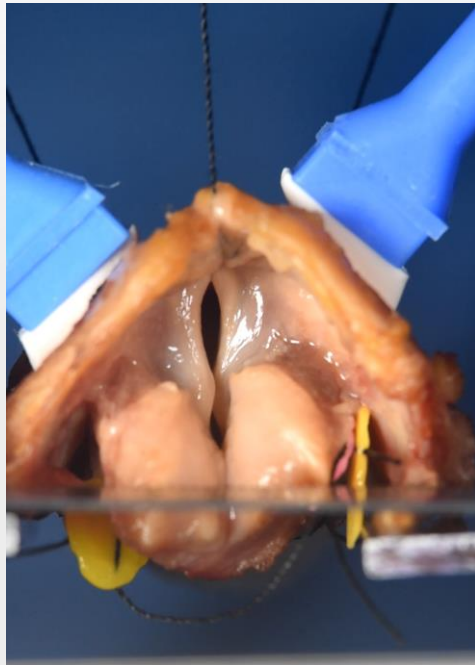
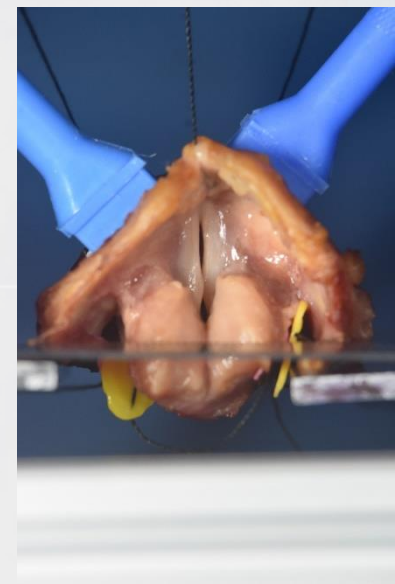
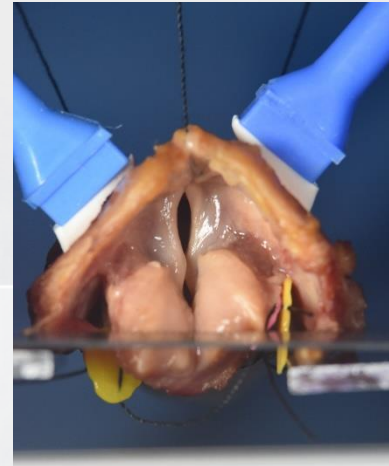
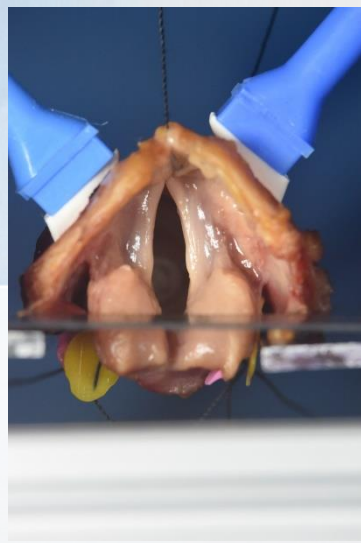
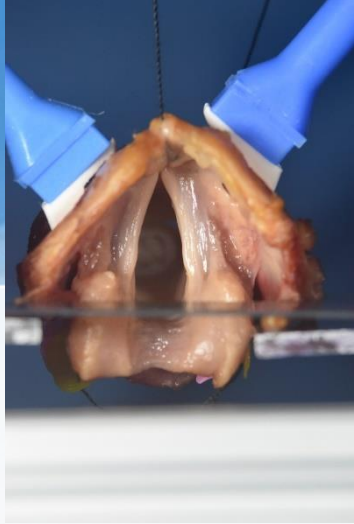

CAL D relache

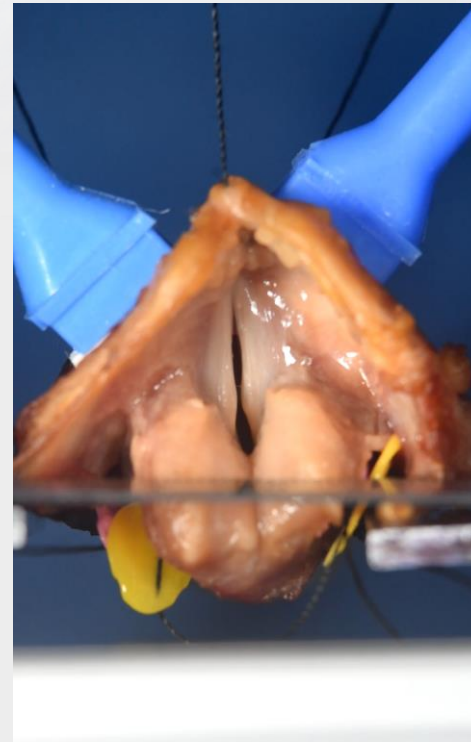

Tension CT, relâche TAD TAG

Perspectives

- Mesure des forces (poussée et traction) appliquées
 - > conception de pièces de maintien en impression 3D
- Activation simultanée des moteurs (gestes)
- Adaptatif en fonction de la position et de la force de poussée ou traction

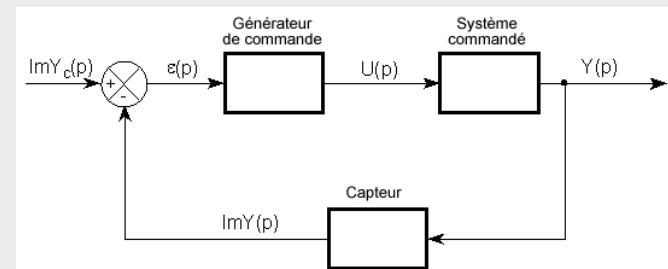
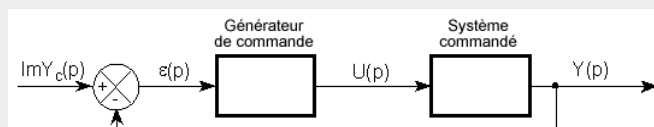

Merci de votre attention